

# 2022 CUSTOM GUITAR DESIGN GUIDE



LIMITED EDITION ROASTED '61 STRATO SUPER HEAVY RELIC®

9235001497





## FOREWORD

A Fender Custom Shop instrument is extraordinary. You know it when you play one—it's definitely more than the sum of its parts. It's filled with intangible, electrifying elements that add a new dimension to your playing experience. It's as if the instrument itself is imbued with history, alive with the spirit of the place where it was built and the devotion of those who crafted it.

The Custom Shop is home to Fender's most skilled and talented builders. It's a bustling, noisy and creatively volcanic place that re-earns its nickname—the Dream Factory—every day. Custom Shop builders are completely dedicated to their art—part craftsman, part artist, part music fan and, more often than not, part mad scientist. They're the best at what they do, and they pour all of their passion, hard-earned knowledge and skill into every instrument they build. It's no ordinary place, and the creations that come from it are no ordinary instruments. Welcome to the Fender Custom Shop.

For players who wish to create a completely custom instrument—anything from a humbucking pickup-equipped banjo to a custom-engraved aluminum-bodied Strat®—we offer Masterbuilt, a singular experience working one-on-one with one of our Master Builders. Custom-Built is for those who prefer to start with one of our time-honored models and personalize the specifications to meet your specific needs. Use this guide to design your very own Masterbuilt or Custom-Built Fender guitar and make your dreams come true.



©2022 Fender Musical Instruments Corporation. FENDER®, STRATOCASTER®, STRAT®, TELECASTER®, TELE®, PRECISION BASS®, P BASS®, Jazz Bass®, J Bass®, ESQUIRE®, Nocaster® and the distinctive headstock designs commonly found on Fender guitars are registered trademarks of FMIC. All rights reserved.

All other trademarks are the property of their respective owners.

All Fender Custom Shop instruments are expertly crafted according to exact order specifications and arrive free of defects. Those instruments not abiding by this policy will be repaired, modified or replaced by us at no cost to you. Consult your local retailer, distributor or the Custom Care™ website ([customcare.fender.com](https://www.customcare.fender.com)) for details.

Fender Musical Instruments Corporation  
17600 North Perimeter Drive  
Scottsdale, AZ 85255-5440  
T: (480) 596-9690  
F: (480) 596-1384

[fendercustomshop.com](https://www.fendercustomshop.com)

All colors, features and specifications are subject to change without notice.





# CONTENTS

Ordering Yours .....	5
Masterbuilt .....	7
Master Builders .....	8
Custom-Built .....	13
Base Models .....	15
Stratocaster Models .....	16
Telecaster Models .....	18
Precision Bass Models .....	20
Jazz Bass Models .....	21
Offset Models .....	22
Aging Styles .....	23
Tonewood Options .....	28
Body Wood .....	28
Neck Wood .....	30
Color Options .....	31
Neck Shapes .....	35
Fret Wire .....	39
Pickup Option .....	41
Wiring Option .....	45
Hardware Options .....	52
Design Guide Order Form .....	58



Fender

BUILD THE BEST

Paulo  
Castano

WHEN YOU'RE READY





**HOW  
TO**

# USE THIS GUIDE

Is there a special Fender instrument that you have been dreaming of your whole life? We have some good news for you! The Fender Custom Shop can take your dreams and shape them into a tonal reality. The process is simple:

## 01 SELECT A BUILD LEVEL

Masterbuilt or Custom-built

## 02 SELECT A CUSTOM SHOP BASE MODEL

Choose from a wide range of guitars and basses

## 03 SELECT AN AGING PACKAGE

## 04 SELECT YOUR OPTIONS

Choose your custom options from our extensive menu of offerings

## 05 ADDITIONAL NOTES

Use the "additional notes" section if your desired options are not listed

## 06 SUBMIT YOUR ORDER

Take this completed design guide to a Custom Shop Showcase Dealer which you can find at [www.fendercustomshop.com/dealers/](http://www.fendercustomshop.com/dealers/)







01



## BUILD LEVEL: MASTERBUILT

In every art form there are those who have mastered their craft so thoroughly, through years of training and experience, their work routinely commands extra acclaim and admiration, not to mention outright awe. These astonishing artisans are the Master Builders of the Fender Custom Shop; a select group of the most talented builders recognized around the world for their matchless skill, limitless imagination and utter devotion to their art.

Crafting a guitar with a Custom Shop Master Builder is the ultimate artistic partnership—simply put, no idea is too crazy and no job too large or too small. They'll walk you through everything—body design, neck shape, tonewoods, pickups, hardware and more—to give you the look, feel and sound that you're searching for. From start to finish the Master Builder will personally ensure that each guitar is built with the highest possible quality and to your exact specifications. Additionally, it's about more than just specifications, it's about making the instrument of your dreams a concrete reality.

# MASTER BUILDERS

Imagine the greatest artists in history gathered under one roof; Michelangelo, DaVinci, Picasso and Dali working next to each other, sharing pigments, knowledge and expertise. The Fender Custom Shop is exactly that, the world's most esteemed luthiers gathered together to create peerless instruments that are astounding works of art—the Master Builders. They are known the world over for their skill and have built instruments for Jeff Beck, Ritchie Blackmore, Eric Clapton, Dick Dale, Mike Dirnt, Bob Dylan, Robben Ford, Buddy Guy, Merle Haggard, Reggie Hamilton, Mark Hoppus, John 5, Keith Richards, Sting and U2... just to name a few!



A large, stylized handwritten signature of Paul Waller in a light grey color, positioned below the photo and extending across the page.

## DALE WILSON



A large, stylized handwritten signature of Dale Wilson in a light grey color, positioned to the right of the photo and overlapping the text area.

Dale Wilson arrived at Fender in 2003, joined the Custom Shop in 2005 and became a Master Builder in 2011. Building guitars has been a driving passion for the California native since childhood. "Ever since I can remember, I've always loved guitars," he said. "I didn't dream of being a rock star; I dreamt of building the ultimate guitar. I was equally enthralled with the guitars just as much as I was with the players."

Woodworking runs in the Wilson family, and the requisite Custom Shop zeal for outstanding craftsmanship has long been part of Dale's DNA. He did repair work and mods in a small guitar shop right out of high school in the late 1980s; subsequently, he moved on to stints at Dobro and Rickenbacker before arriving at Fender, where he worked on Guild, Gretsch and Benedetto guitars before beginning his apprenticeship with various Custom Shop Master Builders.

He enjoys calling upon his extensive and varied experience as a craftsman to create highly distinctive guitars such as the Resophonic Thinline Telecaster®. Wilson also built five beautiful custom guitars for the January 2011 NAMM Show while still an apprentice and was asked to signed the back of the headstocks, garnering him his Master Builder status.

## PAUL WALLER

Paul Waller is a Southern California native with woodworking and luthiery in his blood. He built his first guitar at age 14 in his high school woodshop, joined a cabinet shop right out of high school and, after a stint at a small Southern California guitar maker, enrolled at the acclaimed Roberto-Venn School of Luthiery in Phoenix, from which he graduated in spring of 2000.

Waller joined Fender in 2003. He spent two years working closely with master archtop craftsman Bob Benedetto, and became steeped in the many facets of building techniques from all the Custom Shop's Master Builders. After an extensive seven-year apprenticeship, Waller became a Master Builder in 2010.

His Fender Custom Shop work includes bass guitars for U2's Adam Clayton, a custom Thinline Telecaster for U2 vocalist Bono, Telecaster guitars for the Rolling Stones' Keith Richards and co-work on a Stratocaster for fellow Stones guitarist Ronnie Wood, Stratocaster guitars for Buddy Guy, the Nile Rodgers "Hitmaker" Stratocaster, a custom double-neck Jazzmaster for Queens Of the Stone Age guitarist Troy Van Leeuwen, the George Harrison Tribute Rosewood Telecaster, and the George Harrison Rocky Stratocaster.





## JASON SMITH

A Custom Shop veteran and son of longtime Fender R&D legend Dan Smith, Jason Smith grew up on Fender — “It has always been in my family,” he said, “And I was always extremely interested in everything my father did.”

Born in Rochester, N.Y., and raised in California, Smith remembers meeting guitar greats from about age 5 on through his father’s work with Fender—Eric Clapton, Yngwie Malmsteen, Jeff Beck and Robben Ford, to name only a few. He went to his first big rock concert at age six—Rush—and remembers going backstage with his dad and meeting Geddy Lee after the show. Before he was even in his teens, Smith was going to see Pink Floyd, ZZ Top and many other major artists.

Rock music and Fender are part of Smith’s DNA. He joined the Fender Custom Shop in 1995 and in 2006 completed a five-year apprenticeship under acclaimed Senior Master Builder John English. Among many diverse projects with English, Smith worked on a pair of double-neck Stratocaster guitars for Stone Temple Pilots guitarist Dean DeLeo. He has since crafted fine instruments for players and acts including John 5, Michael Landau, Flea, Josh Klinghoffer, Steve Harris, Reggie Hamilton, Linkin Park, Kenny Wayne Shepherd, Neon Trees and many others.

## TODD KRAUSE



*Todd Krause*

Todd Krause has built exquisitely crafted custom instruments for many of the world’s greatest artists, including Jeff Beck, Eric Clapton, Bob Dylan, David Gilmour, Robbie Robertson, Kenny Wayne Shepherd, Robin Trower, Roger Waters and many others.

His guitar-building apprenticeship began in early 1981 at Jackson/Charvel guitars. Krause arrived at Fender in 1991 and steadily rose through several roles, including one-off instrument builder, R&D model maker, and woodworking machinist. He became a Custom Shop Master Builder in 1997 and has created countless distinctive instruments, all of which embody his personal design philosophy: “Form and function are the biggest part of it,” he said. “It’s about the way an instrument sounds and feels. It has to look cool, and it has to compel you to play.”



## YURIY SHISHKOV

From handcrafting many of his own woodworking tools to showcasing his world-class luthier skills and custom inlay work, Yuriy Shishkov is truly one of the last of the renaissance guitar builders. It was in the small confines of a root cellar in his hometown of Gomel in the former Soviet Union that Shishkov got his start building guitars for friends and colleagues.

When he arrived in the United States in 1990, Shishkov settled in the Chicago area and collaborated with a range of top artists, including late shredder Dimebag Darrel, Jimmy Page and Robert Plant, Nuno Bettencourt and Paul Stanley of Kiss. Shishkov joined the Fender Custom Shop’s Master Builder team in 2000, and continues to craft truly magnificent instruments featuring exquisite detail and inlay work as the Fender Custom Shop’s Principal Master Builder.

*Yuriy Shishkov*



## GREG FESSLER



Greg Fessler came to the Fender Custom Shop in 1990, working his way up through the ranks as an apprentice. He assisted with the Robben Ford signature line of guitars, eventually becoming the sole builder of those instruments and, later, Ford's personal builder. Fessler has built one-off Stratocaster and Telecaster models for a host of players, including Joe Bonnamasa, Jeff Healey, Hank Marvin, John Mayer, Rhonda Smith, Neil Schon and Pete Wentz, to name a few.

Fessler's remarkable abilities as a Master Builder have earned him accolades from many Fender artists and from discerning customers worldwide. His meticulous attention to detail is exemplified in every instrument he creates, each of which is a perfect example of the intense commitment it takes to earn the title of Master Builder.



## RON THORN

Ron Thorn brings his decades of expertise in guitar luthiery, namely inlay work, to The Fender Custom Shop. Thorn's relationship with the Custom Shop team began with his inlay business, Thorn Inlay—which has been the sole inlay provider for the Fender Custom Shop since the mid-90s. He's also built more than 800 custom instruments under the name Thorn Guitars. Thorn is among the first to assume the title Principal Master Builder—one of the highest honors in the Fender Custom Shop and the guitar building community.

*Thorn*



## DENNIS GALUSZKA

Like Fender itself, Dennis Galuszka is a Southern California native. Combining his dual passions for music and woodworking, he began building high-end acoustic guitars during his 13 years as a cabinetmaker. As a working drummer, it was a 1999 audition with one of the Fender Master Builders that led to a job interview and a new kind of steady gig—as an apprentice at the Fender Custom Shop.

After only eight months there, Galuszka was promoted to Master Builder. He has since built finely crafted instruments for influential players including Paul McCartney, Andy Summers, Johnny Marr, Patrick Stump, Mike Dirnt, Sting and many others. He has lent his expertise to a number of truly distinctive instruments, including double-neck guitars and unusual takes on classic Fender designs along with several artist models. "It's all about the feel and sound of an instrument," Galuszka said. "Those things are number one with me, above everything else."





**KYLE MCMILLIN**

Kyle McMillin brings 15 years of musical instrument experience to the Fender Custom Shop. McMillin recently finished a five-year apprenticeship under Principal Master Builder Yuriy Shishkov—working on nearly 1,000 guitars while learning from the esteemed builder. As a newly-minted Master Builder, McMillin is now part of a team of the finest guitar builders—the Fender Custom Shop.

**VINCENT VAN TRIGT**



Originally from the Netherlands, Vincent moved to California in 2005 and began working for Fender immediately. After wearing a variety of hats in different departments, he started in the Custom Shop in 2012.

A 2-year assistant role with Stephen Stern at the Gretsch Custom Shop was followed by a 5-year apprenticeship with John Cruz. During which he worked on many prestigious guitars, including the replica of Gary Moore's '61 Stratocaster, a 30-piece run of the Jimmie and Stevie Ray Vaughan 30th anniversary Stratocasters, and most recently the Phil Lynott Precision Bass.







01



## BUILD LEVEL: CUSTOM BUILT

Your dreams are what make the Fender Custom Shop the reality that it is today. From its inception in 1987, the Custom Shop has grown from two builders to today's more than 50 artisans—a veteran band of builders, each a specialist dedicated to their own area of expertise—working together to build your ideal Fender to your exact specifications. From neck shaping and fretwork to finishing and aging—every step of creation—each Custom Shop craftsman brings years of hard-earned skill and dedication to bear on your custom-built guitar with one goal in mind—to create an instrument and playing experience that can only come from the Fender Custom Shop.

A Fender Custom-Built guitar lets you define your ideal instrument. Begin with one of our base models and choose from our vast selection of options to customize it as little or as much as you want to meet your personal needs, aesthetic taste and playing style.

Whatever shape your dream may be, our luthiers stand ready to craft an instrument that will unlock your utmost creativity and self-expression. Their passion is bringing your dreams to reality, to create the ultimate instrument—one personally customized exclusively for you.



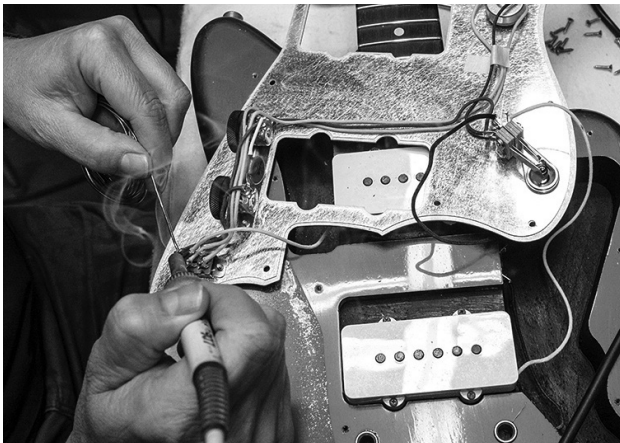



# 02



## SELECT A BASE MODEL

Each base model includes specifications listed as period accurate but can be customized based on the player's playing style and taste.



# STRATOCASTER BASE MODELS

## 1955 STRATOCASTER

SHOWN IN 2-COLOR SUNBURST



<b>BODY WOOD</b>	ASH
<b>BODY FINISH</b>	NITROCELLULOSE LACQUER
<b>NECK WOOD</b>	MAPLE
<b>NECK SHAPE</b>	'55 "U"
<b>FINGERBOARD</b>	1-PIECE MAPLE
<b>RADIUS</b>	7.25"
<b>FRET SIZE</b>	VINTAGE
<b>FACE DOTS</b>	BLACK MICARTA – WIDE SPACING
<b>NUT</b>	MICARTA
<b>TUNERS</b>	FENDER GOTOH VINTAGE
<b>HARDWARE</b>	NICKEL / CHROME
<b>BRIDGE</b>	VINTAGE SYNCHRONIZED TREMOLO
<b>PICKGUARD</b>	1-PLY WHITE
<b>WIRING</b>	VINTAGE STRAT W/ 3-WAY SWITCH
<b>PICKUPS</b>	FCS 1950S STRAT

## 1956 STRATOCASTER

SHOWN IN WHITE-BLONDE



<b>BODY WOOD</b>	ALDER
<b>BODY FINISH</b>	NITROCELLULOSE LACQUER
<b>NECK WOOD</b>	MAPLE
<b>NECK SHAPE</b>	10/56 "V"
<b>FINGERBOARD</b>	1-PIECE MAPLE
<b>RADIUS</b>	7.25"
<b>FRET SIZE</b>	VINTAGE
<b>FACE DOTS</b>	BLACK MICARTA – WIDE SPACING
<b>NUT</b>	MICARTA
<b>TUNERS</b>	FENDER GOTOH VINTAGE
<b>HARDWARE</b>	NICKEL / CHROME
<b>BRIDGE</b>	VINTAGE SYNCHRONIZED TREMOLO
<b>PICKGUARD</b>	1-PLY WHITE
<b>WIRING</b>	VINTAGE STRAT W/ 3-WAY SWITCH
<b>PICKUPS</b>	FCS 1950S STRAT

## 1960 STRATOCASTER

SHOWN IN DAKOTA RED



<b>BODY WOOD</b>	ALDER
<b>BODY FINISH</b>	NITROCELLULOSE LACQUER
<b>NECK WOOD</b>	MAPLE
<b>NECK SHAPE</b>	'60S OVAL "C"
<b>FINGERBOARD</b>	SLAB ROSEWOOD
<b>RADIUS</b>	7.25"
<b>FRET SIZE</b>	VINTAGE
<b>FACE DOTS</b>	CLAY – WIDE SPACING
<b>NUT</b>	MICARTA
<b>TUNERS</b>	FENDER GOTOH VINTAGE
<b>HARDWARE</b>	NICKEL / CHROME
<b>BRIDGE</b>	VINTAGE SYNCHRONIZED TREMOLO
<b>PICKGUARD</b>	3-PLY WHITE
<b>WIRING</b>	VINTAGE STRAT W/ 3-WAY SWITCH
<b>PICKUPS</b>	FCS 1960S STRAT

## 1963 STRATOCASTER

SHOWN IN 3-COLOR SUNBURST



<b>BODY WOOD</b>	ALDER
<b>BODY FINISH</b>	NITROCELLULOSE LACQUER
<b>NECK WOOD</b>	MAPLE
<b>NECK SHAPE</b>	60S OVAL "C"
<b>FINGERBOARD</b>	ROUND-LAM ROSEWOOD
<b>RADIUS</b>	7.25"
<b>FRET SIZE</b>	VINTAGE
<b>FACE DOTS</b>	CLAY – NARROW SPACING
<b>NUT</b>	MICARTA
<b>TUNERS</b>	FENDER GOTOH VINTAGE
<b>HARDWARE</b>	NICKEL / CHROME
<b>BRIDGE</b>	VINTAGE SYNCHRONIZED TREMOLO
<b>PICKGUARD</b>	3-PLY WHITE
<b>WIRING</b>	VINTAGE STRAT W/ 3-WAY SWITCH
<b>PICKUPS</b>	FCS 1960S STRAT



## 1965 STRATOCASTER

SHOWN IN AZTEC GOLD



**BODY WOOD** ALDER  
**BODY FINISH** NITROCELLULOSE LACQUER  
**NECK WOOD** MAPLE  
**NECK SHAPE** '65 "C"  
**FINGERBOARD** ROUND-LAM ROSEWOOD  
**RADIUS** 7.25"  
**FRET SIZE** VINTAGE  
**FACE DOTS** PEARL – NARROW SPACING  
**NUT** MICARTA  
**TUNERS** FENDER GOTOH VINTAGE  
**HARDWARE** NICKEL / CHROME  
**BRIDGE** VINTAGE SYNCHRONIZED TREMOLO  
**PICKGUARD** 3-PLY WHITE  
**WIRING** VINTAGE STRAT W/ 3-WAY SWITCH  
**PICKUPS** FCS 1965 STRAT

## 1969 STRATOCASTER

SHOWN IN SONIC BLUE



**BODY WOOD** ALDER  
**BODY FINISH** NITROCELLULOSE LACQUER  
**NECK WOOD** MAPLE – URETHANE FINISH  
**NECK SHAPE** '69 "C"  
**FINGERBOARD** ROUND-LAM ROSEWOOD OR MAPLE  
**RADIUS** 7.25"  
**FRET SIZE** VINTAGE  
**FACE DOTS** PEARL WHITE OR BLACK  
**NUT** MICARTA  
**TUNERS** SCHALLER "F"  
**HARDWARE** NICKEL / CHROME  
**BRIDGE** VINTAGE SYNCHRONIZED TREMOLO  
**PICKGUARD** 3-PLY WHITE  
**WIRING** VINTAGE STRAT W/ 3-WAY SWITCH  
**PICKUPS** FCS 1969 STRAT

## TELECASTER BASE MODELS

### 1951 NOCASTER

SHOWN IN HONEY BLONDE



**BODY WOOD** ASH  
**BODY FINISH** NITROCELLULOSE LACQUER  
**NECK WOOD** MAPLE  
**NECK SHAPE** NOCASTER "U"  
**FINGERBOARD** 1-PIECE MAPLE  
**RADIUS** 7.25"  
**FRET SIZE** F VINTAGE  
**FACE DOTS** BLACK MICARTA – NARROW SPACING  
**NUT** MICARTA  
**TUNERS** FENDER GOTOH VINTAGE  
**HARDWARE** NICKEL / CHROME  
**BRIDGE** VINTAGE WITH BRASS SADDLES  
**PICKGUARD** 1-PLY BLACK  
**WIRING** VINTAGE TELE W/ 3-WAY SWITCH  
**PICKUPS** FCS 1951 NOCASTER

### 1952 TELECASTER

SHOWN IN 2-COLOR SUNBURST



**BODY WOOD** ASH  
**BODY FINISH** NITROCELLULOSE LACQUER  
**NECK WOOD** MAPLE  
**NECK SHAPE** '52 "U"  
**FINGERBOARD** 1-PIECE MAPLE  
**RADIUS** 7.25"  
**FRET SIZE** VINTAGE  
**FACE DOTS** BLACK MICARTA – WIDE SPACING  
**NUT** MICARTA  
**TUNERS** FENDER GOTOH VINTAGE  
**HARDWARE** NICKEL / CHROME  
**BRIDGE** VINTAGE WITH BRASS SADDLES  
**PICKGUARD** 1-PLY BLACK  
**WIRING** VINTAGE TELE W/ 3-WAY SWITCH  
**PICKUPS** FCS 1951 NOCASTER



## 1960 TELECASTER

SHOWN IN WHITE BLONDE



**BODY WOOD** ALDER  
**BODY FINISH** NITROCELLULOSE LACQUER  
**NECK WOOD** MAPLE  
**NECK SHAPE** '60S OVAL "C"  
**FINGERBOARD** SLAB ROSEWOOD  
**RADIUS** 7.25"  
**FRET SIZE** VINTAGE  
**FACE DOTS** CLAY - NARROW SPACING  
**NUT** MICARTA  
**TUNERS** FENDER GOTOH VINTAGE  
**HARDWARE** NICKEL / CHROME  
**BRIDGE** VINTAGE WITH THREADED SADDLES  
**PICKGUARD** 3-PLY WHITE  
**WIRING** VINTAGE TELE W/ 3-WAY SWITCH  
**PICKUPS** FCS '60 - '63 TELECASTER

## 1960 TELECASTER CUSTOM

SHOWN IN BLACK



**BODY WOOD** DOUBLE-BOUND ALDER  
**BODY FINISH** NITROCELLULOSE LACQUER  
**NECK WOOD** MAPLE  
**NECK SHAPE** | '60S OVAL "C"  
**FINGERBOARD** | SLAB ROSEWOOD  
**RADIUS** 7.25"  
**FRET SIZE** VINTAGE  
**FACE DOTS** CLAY  
**NUT** MICARTA  
**TUNERS** FENDER GOTOH VINTAGE  
**HARDWARE** NICKEL / CHROME  
**BRIDGE** VINTAGE WITH THREADED SADDLES  
**PICKGUARD** 3-PLY WHITE  
**WIRING** VINTAGE TELE W/ 3-WAY SWITCH  
**PICKUPS** FCS '60 - '63 TELECASTER

## 1963 TELECASTER

SHOWN IN LAKE PLACID BLUE



**BODY WOOD** ALDER  
**BODY FINISH** NITROCELLULOSE LACQUER  
**NECK WOOD** MAPLE  
**NECK SHAPE** '60S OVAL "C"  
**FINGERBOARD** ROUND-LAM ROSEWOOD  
**RADIUS** 7.25"  
**FRET SIZE** VINTAGE  
**FACE DOTS** CLAY  
**NUT** MICARTA  
**TUNERS** FENDER GOTOH VINTAGE  
**HARDWARE** NICKEL / CHROME  
**BRIDGE** VINTAGE WITH THREADED SADDLES  
**PICKGUARD** 3-PLY WHITE  
**WIRING** VINTAGE TELE W/ 3-WAY SWITCH  
**PICKUPS** FCS '60 - '63 TELECASTER

## 1967 TELECASTER

SHOWN IN CANDY APPLE RED



**BODY WOOD** ALDER  
**BODY FINISH** NITROCELLULOSE LACQUER  
**NECK WOOD** MAPLE  
**NECK SHAPE** '60S OVAL "C"  
**FINGERBOARD** ROSEWOOD OR MAPLE  
**RADIUS** 7.25"  
**FRET SIZE** VINTAGE  
**FACE DOTS** PEARL WHITE OR BLACK MICARTA  
**NUT** MICARTA  
**TUNERS** SCHALLER "F"  
**HARDWARE** NICKEL / CHROME  
**BRIDGE** VINTAGE WITH THREADED SADDLES  
**PICKGUARD** 3-PLY WHITE  
**WIRING** VINTAGE TELE W/ 3-WAY SWITCH  
**PICKUPS** FCS 1967 TELECASTER



## 1959 ESQUIRE

SHOWN IN 3-COLOR SUNBURST



**BODY WOOD** ASH  
**BODY FINISH** NITROCELLULOSE LACQUER  
**NECK WOOD** MAPLE  
**NECK SHAPE** '59 "C"  
**FINGERBOARD** SLAB ROSEWOOD OR MAPLE  
**RADIUS** 7.25"  
**FRET SIZE** VINTAGE  
**FACE DOTS** MICARTA BLACK - WIDE SPACING  
**NUT** MICARTA  
**TUNERS** FENDER GOTOH VINTAGE  
**HARDWARE** NICKEL / CHROME  
**BRIDGE** VINTAGE '59 W/THREADED  
**PICKGUARD** 1-PLY PARCHMENT  
**WIRING** VINTAGE ESQUIRE 3-WAY SWITCH  
**PICKUPS** FCS VINTAGE TELECASTER

## 1950's THINLINE TELECASTER

SHOWN IN 2-COLOR SUNBURST



**BODY WOOD** ASH  
**BODY FINISH** NITROCELLULOSE LACQUER  
**NECK WOOD** MAPLE  
**NECK SHAPE** NOCASTER "U"  
**FINGERBOARD** 1-PIECE MAPLE  
**RADIUS** 7.25"  
**FRET SIZE** VINTAGE  
**FACE DOTS** CLAY - NARROW SPACING  
**NUT** MICARTA  
**TUNERS** FENDER GOTOH VINTAGE  
**HARDWARE** NICKEL / CHROME  
**BRIDGE** VINTAGE WITH BRASS SADDLES  
**PICKGUARD** 1-PLY WHITE  
**WIRING** VINTAGE TELE W/ 3-WAY SWITCH  
**PICKUPS** FCS 1951 NOCASTER

## PRECISION BASS BASE MODELS

### 1955 PRECISION BASS

SHOWN IN VINTAGE BLONDE



**BODY WOOD** ASH  
**BODY FINISH** NITROCELLULOSE LACQUER  
**NECK WOOD** QUARTERSAWN MAPLE  
**NECK SHAPE** '55 PBASS SOFT "V"  
**FINGERBOARD** 1-PIECE MAPLE  
**RADIUS** 7.25"  
**FRET SIZE** VINTAGE  
**FACE DOTS** CLAY  
**NUT** MICARTA  
**TUNERS** FENDER GOTOH REVERSE  
**HARDWARE** NICKEL / CHROME  
**BRIDGE** VINTAGE  
**PICKGUARD** 1-PLY WHITE  
**WIRING** VINTAGE PRECISION BASS  
**PICKUPS** FCS 1950S PRECISION BASS

### 1959 PRECISION BASS

SHOWN IN BLACK



**BODY WOOD** ALDER  
**BODY FINISH** NITROCELLULOSE LACQUER  
**NECK WOOD** QUARTERSAWN MAPLE  
**NECK SHAPE** '60S PBASS OVAL "C"  
**FINGERBOARD** SLAB ROSEWOOD  
**RADIUS** 7.25"  
**FRET SIZE** VINTAGE  
**FACE DOTS** CLAY  
**NUT** MICARTA  
**TUNERS** FENDER GOTOH REVERSE  
**HARDWARE** NICKEL / CHROME  
**BRIDGE** VINTAGE  
**PICKGUARD** GOLD ANODIZED  
**WIRING** VINTAGE PRECISION BASS  
**PICKUPS** FCS '59 - '62 BASS



## 1960 PRECISION BASS

SHOWN IN 3-COLOR SUNBURST



<b>BODY WOOD</b>	ASH
<b>BODY FINISH</b>	NITROCELLULOSE LACQUER
<b>NECK WOOD</b>	MAPLE
<b>NECK SHAPE</b>	'60S PBASS OVAL "C"
<b>FINGERBOARD</b>	SLAB ROSEWOOD
<b>RADIUS</b>	7.25"
<b>FRET SIZE</b>	VINTAGE
<b>FACE DOTS</b>	CLAY
<b>NUT</b>	MICARTA
<b>TUNERS</b>	FENDER GOTOH REVERSE
<b>HARDWARE</b>	NICKEL / CHROME
<b>BRIDGE</b>	VINTAGE
<b>PICKGUARD</b>	4-PLY TORTOISE SHELL
<b>WIRING</b>	VINTAGE PRECISION BASS
<b>PICKUPS</b>	FCS '59 - '62 BASS

## JAZZ BASS BASE MODEL

20

## 1964 JAZZ BASS

SHOWN IN SONIC BLUE



<b>BODY WOOD</b>	ALDER
<b>BODY FINISH</b>	NITROCELLULOSE LACQUER
<b>NECK WOOD</b>	MAPLE
<b>NECK SHAPE</b>	'60 "U"
<b>FINGERBOARD</b>	ROUND-LAM ROSEWOOD
<b>RADIUS</b>	7.25"
<b>FRET SIZE</b>	VINTAGE
<b>FACE DOTS</b>	CLAY
<b>NUT</b>	MICARTA
<b>TUNERS</b>	FENDER GOTOH REVERSE
<b>HARDWARE</b>	NICKEL / CHROME
<b>BRIDGE</b>	VINTAGE
<b>PICKGUARD</b>	4-PLY TORTOISE SHELL
<b>WIRING</b>	VINTAGE JAZZ BASS
<b>PICKUPS</b>	FCS VINTAGE JAZZ BASS



# OFFSET BASE MODELS

## 1962 JAZZMASTER

SHOWN IN SURF GREEN



<b>BODY WOOD</b>	ALDER
<b>BODY FINISH</b>	NITROCELLULOSE LACQUER
<b>NECK WOOD</b>	MAPLE
<b>NECK SHAPE</b>	JAZZMASTER "C"
<b>FINGERBOARD</b>	SLAB ROSEWOOD
<b>RADIUS</b>	7.25"
<b>FRET SIZE</b>	VINTAGE
<b>FACE DOTS</b>	CLAY
<b>NUT</b>	MICARTA
<b>TUNERS</b>	FENDER GOTOH VINTAGE
<b>HARDWARE</b>	NICKEL / CHROME
<b>BRIDGE</b>	VINTAGE JAGUAR/JAZZMASTER
<b>PICKGUARD</b>	3-PLY WHITE
<b>WIRING</b>	VINTAGE JAZZMASTER
<b>PICKUPS</b>	FCS JAZZMASTER

## 1962 JAGUAR

SHOWN IN FIESTA RED



<b>BODY WOOD</b>	ALDER
<b>BODY FINISH</b>	NITROCELLULOSE LACQUER
<b>NECK WOOD</b>	MAPLE
<b>NECK SHAPE</b>	JAGUAR "C"
<b>FINGERBOARD</b>	SLAB ROSEWOOD
<b>RADIUS</b>	7.25"
<b>FRET SIZE</b>	VINTAGE
<b>FACE DOTS</b>	CLAY
<b>NUT</b>	MICARTA
<b>TUNERS</b>	FENDER GOTOH VINTAGE
<b>HARDWARE</b>	NICKEL / CHROME
<b>BRIDGE</b>	VINTAGE JAGUAR/JAZZMASTER
<b>PICKGUARD</b>	3-PLY WHITE
<b>WIRING</b>	VINTAGE JAGUAR
<b>PICKUPS</b>	FCS JAGUAR

## BASS VI

SHOWN IN 3-COLOR SUNBURST



<b>BODY WOOD</b>	ALDER
<b>BODY FINISH</b>	NITROCELLULOSE LACQUER
<b>NECK WOOD</b>	QUARTERSAWN MAPLE
<b>NECK SHAPE</b>	"C"
<b>FINGERBOARD</b>	SLAB ROSEWOOD
<b>RADIUS</b>	7.25"
<b>FRET SIZE</b>	VINTAGE
<b>FACE DOTS</b>	CLAY
<b>NUT</b>	MICARTA
<b>TUNERS</b>	FENDER GOTOH VINTAGE
<b>HARDWARE</b>	NICKEL / CHROME
<b>BRIDGE</b>	VINTAGE JAGUAR
<b>PICKGUARD</b>	4-PLY TORTOISE SHELL
<b>WIRING</b>	VINTAGE BASS VI
<b>PICKUPS</b>	FCS JAGUAR





1558902803 ANCHO POBLANO STRAT - 2-COLOR SUNBURST

1558902801 ANCHO POBLANO STRAT - WHITE BLONDE



# 03



## SELECT AN AGING STYLE



## NEW OLD STOCK(NOS)

SHOWN IN 1956 STRATOCASTER IN WHITE BLONDE

Models from the past that have survived to the present day looking brand new. An all-lacquer finish that looks as if it hasn't aged at all - as if you went back in time and bought it.



## CLOSET CLASSIC

SHOWN IN LIMITED EDITION 1958 JAZZMASTER IN 2-COLOR SUNBURST

No real playing wear, but more subtle indications of the ages, such as a finish that has lost its sheen, mild discoloration of plastic parts, metal hardware showing slight oxidation, "mild" finish checking and minor surface scratches on the body and headstock.



24

## DLX CLOSET CLASSIC

SHOWN IN POST-MODERN TELECASTER IN FADED FIREMIST SILVER

Well taken care of and religiously polished throughout the years. The owner of this guitar took pride in keeping it clean and shiny. Over time the finish started showing age and like a fine wine it evolved into something complex and refined. Moderate finish checking, oxidation of hardware, and mild discoloration of parts give this finish its distinct look and feel.



## JOURNEYMAN RELIC®

SHOWN IN 1959 JAZZMASTER IN AGED FIESTA RED

Handed down or changed hands through the years, but mostly played around the house, with the occasional jam session or weekend gig. Has been well taken care of over the years but has finish checking, some "friendly" down-to-the-wood nicks and dings, dullish hardware, and moderate playing wear—a very lucky find.



## RELIC®

SHOWN IN 1960 STRATOCASTER IN AGED DAPHNE BLUE

The authentic worn-in wear of a guitar that has experienced many years of regular use in clubs and bars. Marks that tell a story, finish checking all over the body; scars, dings and dents from bridge to headstock.



## HEAVY RELIC®

SHOWN IN 1953 TELECASTER IN BUTTERSCOTCH BLONDE

The heaviest of the relic treatments, designed to evoke decades of the most punishing play and touring. From serious dinged and wear to intensely discolored hardware and finish, the true battle-hardened workhorse.







LIMITED EDITION '61 STRAT® HEAVY  
RELIC®, AGED VINTAGE WHITE OVER  
3-COLOR SUNBURST - 9231013161



# 04



## SELECT YOUR OPTIONS



# TONewood OPTIONS

## BODY WOOD OPTIONS

---



### ALDER

A fantastic tone wood long used by Fender for its electric guitar bodies, alder is noted for bright, balanced and resonant tone with pronounced upper midrange, excellent sustain and sharp attack. It also features large, swirling grain patterns.



### ASH

Strong and dense, ash is a longtime Fender classic for electric instrument bodies. Notably resonant and sweet sounding, it's characterized by well-defined midrange and strong low end.



### MAHOGANY

A dense, dark tone wood that yields warm tone and midrange bite, mahogany is a great option that adds a unique and complex sonic and visual twist to your build.

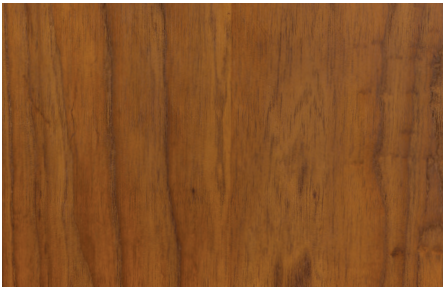

### ROASTED ASH

Strong and ultra-stable, a roasted ash body is a thing of beauty. Not only does the roasting process accentuate the figuring of the wood, it also crystallizes the sap, giving it the sound of old wood.



### OKUME

A warm-sounding tone wood with figured grain patterns that make it an excellent choice for a guitar body spread.



### ROASTED ALDER

The roasting process will darken the wood while keeping it very stable and durable. As with a slab of wood that has dried over the years, the properties change slightly and add to the richness and depth of tone.

# QUILT/FLAME TOP OPTIONS

---



## QUILT MAPLE TOP

A beautifully figured wood, quilt maple works especially well with transparent and natural finishes that allow the flowing grain to show through.



## AA FLAME MAPLE TOP

AA flame maple features tiger-like striping in the wood grain. Many believe that this is caused by the tree swaying in the wind, the minerals in the ground and other ephemeral variables. We aren't positive about that, but we do know it provides a strikingly beautiful look to any instrument neck or body.



## AAA FLAME MAPLE TOP

AAA flame maple sorts a more intense concentration of figuring than AA Flame. The bold stripes are always a beautiful touch in natural and transparent finishes.



## SPALTED MAPLE

Spalted maple combines excellent strength and bright, crisp tone with incredibly unique and captivating figured lines and streaks to give your instrument an elegant look and sound.



## KOA

Beautiful and highly stable tone-wood prized for its resonance, workability and attractive figure.



## MAPLE BURL

Highly figured maple top used on our Artisan models with a gorgeous marbled swirl.



# NECK WOOD OPTIONS

---



## MAPLE NECK

Light in color, with a bright, chimey tone, maple is favorite amongst many Fender players for its look, feel and tone.



## FLAME MAPLE

With its strong, vibrant figure, flame maple is one of our favorite ways to liven up the look of a maple neck.



## BIRDSEYE MAPLE

Small round figuring in the wood which produces small "birdseye" markings. Used on many Custom Shop guitars, a birdseye maple neck will add a unique and striking look to your guitar.



## ROASTED MAPLE NECK

Roasted maple creates an aged and dark look to the wood as well as making it more resonant and slightly lighter in weight.

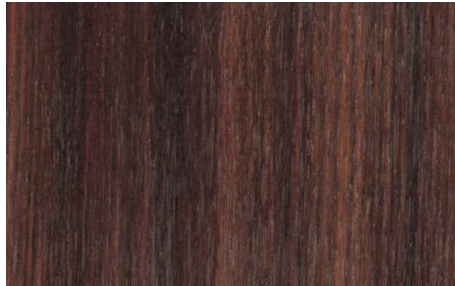

## ROSEWOOD NECK

Darker in color and warmer in tone than maple, rosewood can be specially sorted for a darker color. In 1959, all Fenders were outfitted with rosewood fingerboards, which was a significant departure from the look and tone of the previous maple boards.



## ROASTED FLAME MAPLE

Roasting maple brings out the figure and creates a caramelized dark tiger striping.

# NECK TINT OPTIONS

---



## LIGHT TINT



## MEDIUM TINT



## DARK TINT



SELECT A  
COLOR OPTION





00 3 COLOR SUNBURST



01 WHITE BLONDE

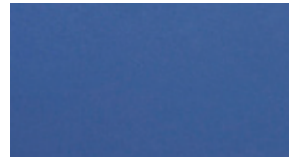

02 LAKE PLACID BLUE



03 2 COLOR SUNBURST



04 DAPHNE BLUE

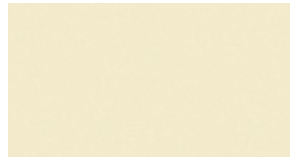

05 OLYMPIC WHITE



06 06 | BLACK

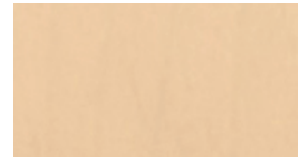

07 VINTAGE BLONDE



08 OCEAN TURQUOISE



09 CANDY APPLE RED

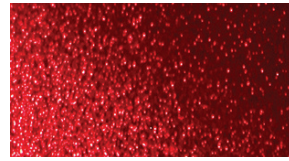

12 RED SPARKLE

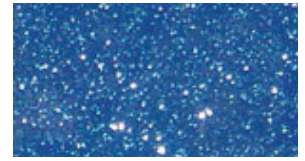

13 BLUE SPARKLE



15 HOT ROD RED

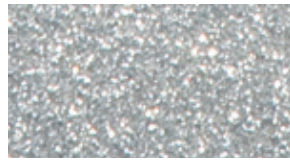

17 SILVER SPARKLE

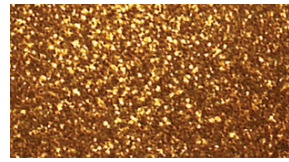

18 GOLD SPARKLE



19 SAGE GREEN METALLIC



20 AMBER



21 NATURAL



22 SUNSET ORANGE TRANS



23 PEARL WHITE



24 INCA SILVER



25 25 | CHROME RED



26 VIOLET



27 SAPPHIRE BLUE TRANS



28 CRIMSON BURST



29 BLUE AGAVE



30 CHERRY SUNBURST



31 AGED CHERRY SUNBURST



32 BROWN SUNBURST

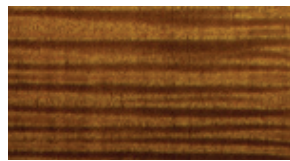

33 VIOLIN BURST



34 AGED NATURAL



36 BLUE BURST



37 ANTIQUE BURST



38 CRIMSON TRANS



39 EBONY TRANS



40 FIESTA RED



41 VINTAGE WHITE



42 MERCEDES BLUE



43 PEWTER



44 SHORELINE GOLD



45 TEAL GREEN METALLIC



46 SHERWOOD GREEN MET.



47 SIENNA SUNBURST



48 TEAL GREEN TRANS



49 SEA FOAM GREEN



52 TOBACCO BURST



53 FIRE MIST GOLD



54 DAKOTA RED

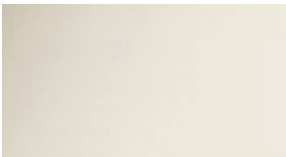

55 FROST WHITE

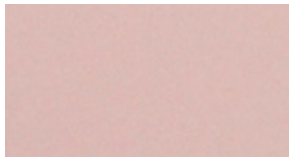

56 SHELL PINK



57 SURF GREEN



58 TORINO RED

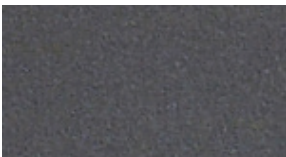

59 BLACK PEARL



60 EMERALD GREEN TRANS

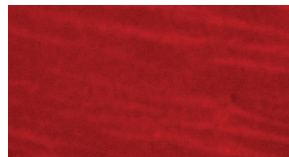

61 BING CHERRY TRANS



62 COBALT BLUE TRANS



63 GRAFFITI YELLOW



66 BURGUNDY MIST MET.



67 HONEY BLONDE



68 LIME GREEN



70 CADMIUM ORANGE



71 CANDY GREEN



72 SONIC BLUE



73 MIDNIGHT BLUE



74 AQUA MARINE METALLIC



75 MIDNIGHT WINE



76 MIDNIGHT PURPLE



77 FROST RED



78 AZTEC GOLD



79 FROST GOLD

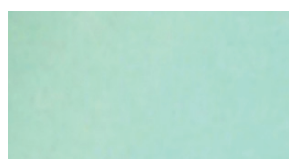

81 SURF PEARL

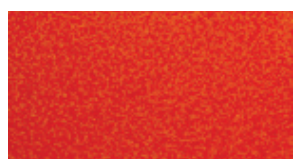

82 CANDY TANGERINE





**83** BLUE ICE METALLIC



**84** COPPER



**85** BRIGHT AMBER MET



**86** BRIGHT SAPPHIRE MET.



**87** COBALT BLUE METALLIC



**88** DESERT SUNSET



**89** DESERT SAND



**90** BALTIC BLUE



**92** WALNUT



**93** PURPLE METALLIC



**94** PURPLE TRANS



**95** | AGED VINTAGE WHITE



**96** ORANGE



**97** CHOCOLATE 3 TONE SB

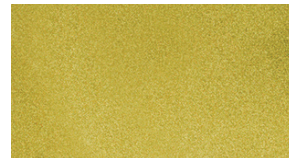

**98** HLE GOLD



**99** NOCASTER BLONDE



**BG** BRITISH RACING GREEN



**BT** BUTTERSCOTCH BLONDE

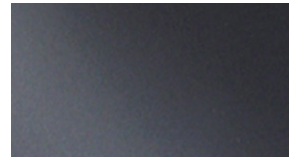

**CF** CHARCOAL FROST MET



**CR** CIMARRON RED

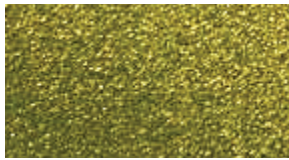

**CS** CHARTREUSE SPARKLE



**DB** DIRTY WHITE BLONDE



**HB** HONEY BURST

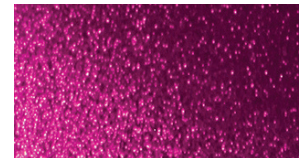

**MS** MAGENTA SPARKLE

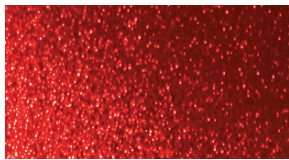

**OS** ORANGE SPARKLE

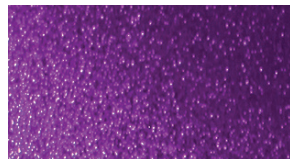

**PS** PURPLE SPARKLE



**SR** SEMINOLE RED

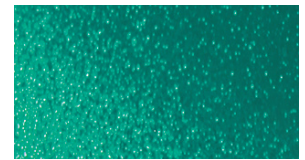

**SS** SEAFOAM GREEN SPARKLE



**TT** TAOS TURQUOISE



**•** YOUR COLOR  
\*Example shown in Fiesta Red.



**•** YOUR COLOR AGED  
Adds a golden tint to simulate aging.

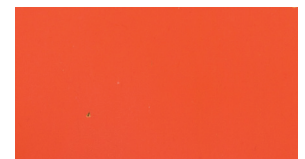

**•** YOUR COLOR FADED  
Creates the look of a color that has faded over time.



SELECT A  
**NECK SHAPE**



# GUITAR NECK SHAPES

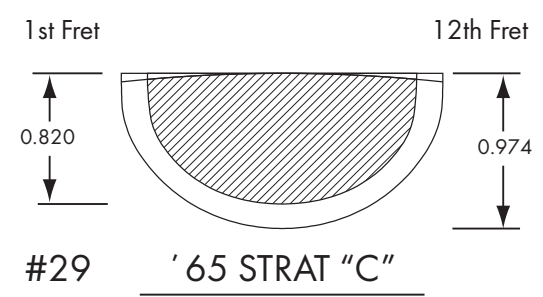
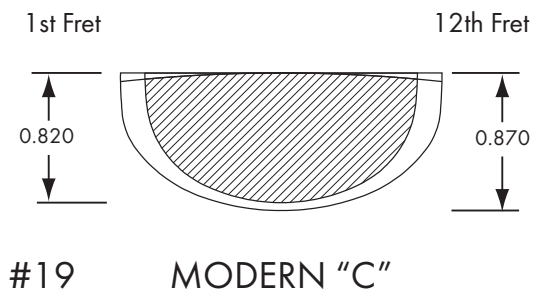
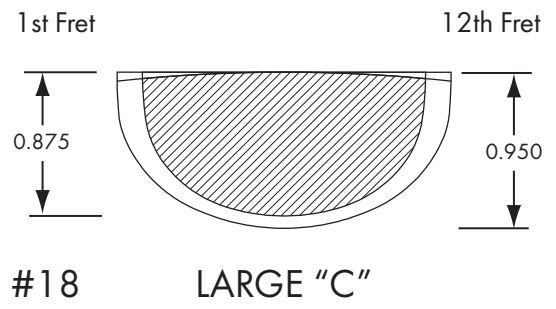
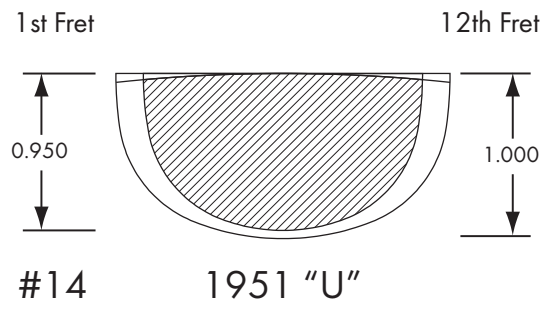
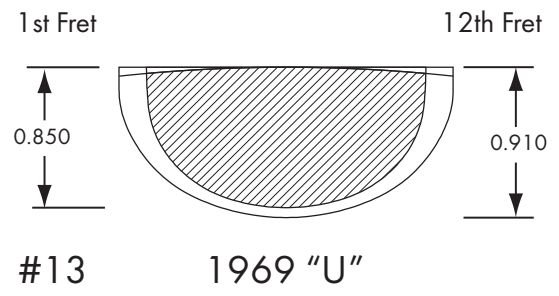
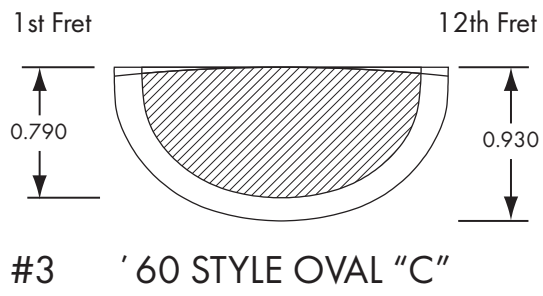
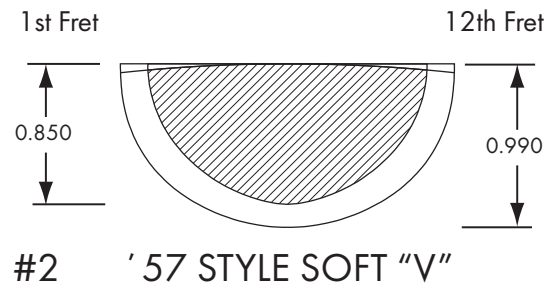
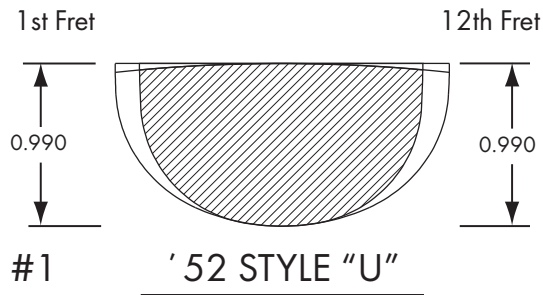

# GUITAR NECK SHAPES (CONT.)

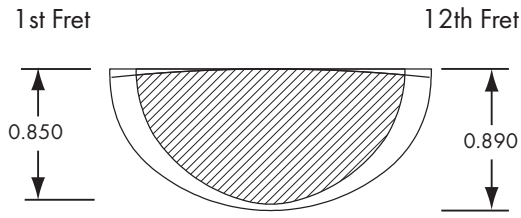

#20 MODERN "V"

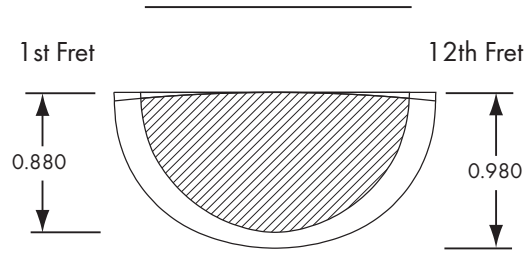

#23 10/56 "V"

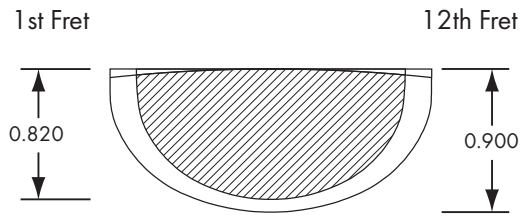

#36 JAGUAR /  
JAZZMASTER "C"

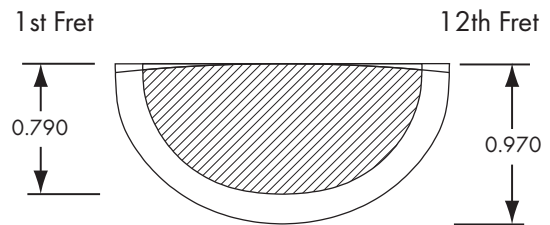

#28 '59 "C"

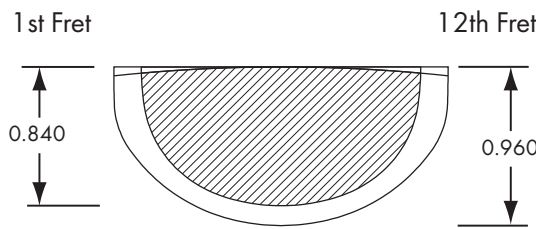

#51 '66 STRAT OVAL "C"

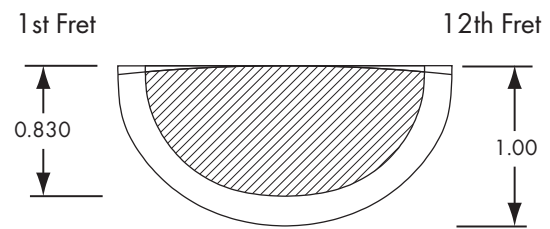

#59 '63 "C"



# BASS NECK SHAPES

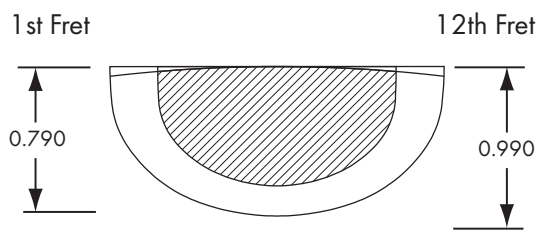

#8 '60 J BASS "U"

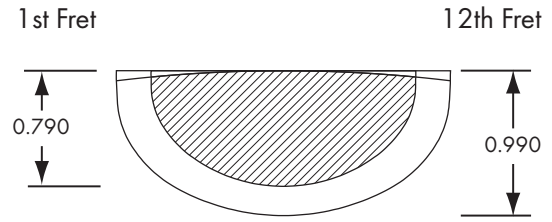

#7 '60 P BASS OVAL "C"

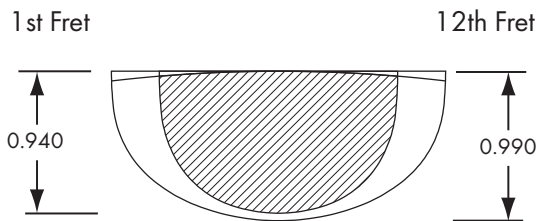

#12 '51 P BASS "U"

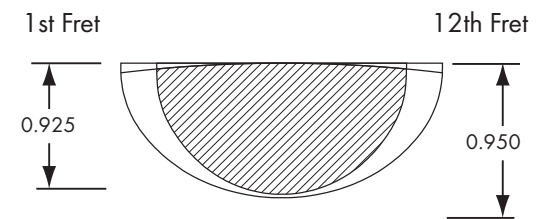

#30 '55 P BASS SOFT "V"

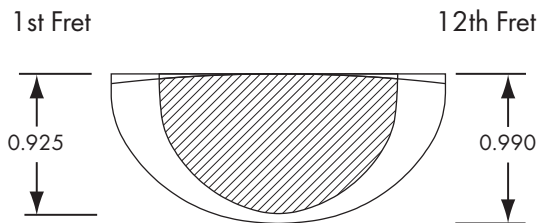

#6 '57 BASS SOFT "V"

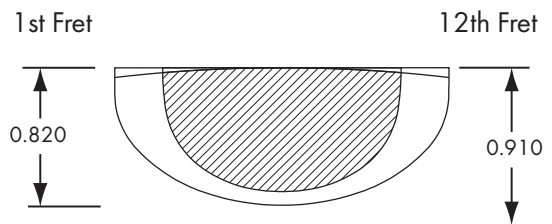

#26 CC JAZZ BASS  
4 STRING "C"

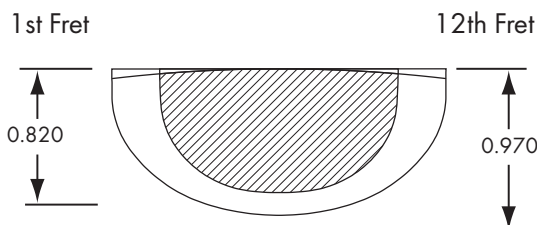

#40 '75 JAZZ BASS



## SELECT A FRET WIRE

Custom Shop frets are made from only the highest quality nickel, and can be made in a variety of different heights and thicknesses. Larger frets tend to account for easier string bending. Smaller frets are “true to vintage” in many cases, and facilitate easier chording.

Medium jumbo frets are designed to be the perfect marriage between small vintage frets and modern jumbo frets. Keep the following examples in mind when choosing the frets that you want on your guitar.



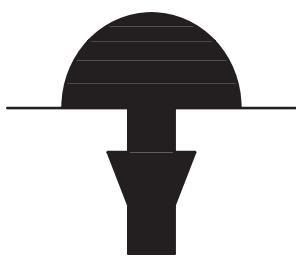

## VINTAGE 45085

H: 0.045"

W: 0.085"

Our smallest wire, slightly larger than Fender's original wire.

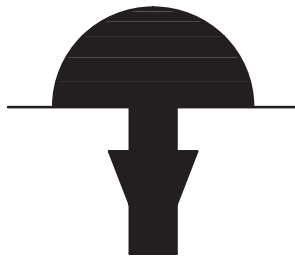

## MEDIUM VINTAGE 47095

H: 0.047"

W: 0.095"

Slightly lower than 6105.

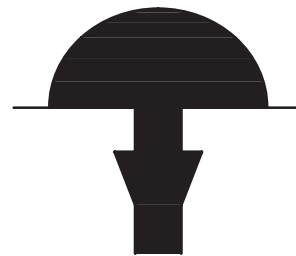

## MEDIUM JUMBO 6150

H: 0.047"

W: 0.104"

A popular middle of the road wire, not too wide, not too tall.

\*Also available in Stainless Steel on Master Built guitars only.

40

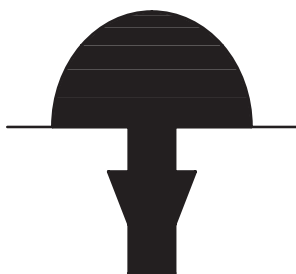

## NARROW TALL 6105

H: 0.055"

W: 0.095"

Our most popular wire. A good alternative if vintage wire feels too small for you.

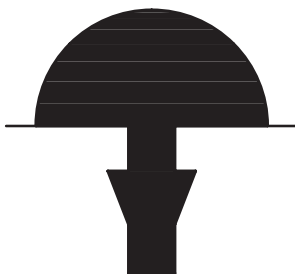

## JUMBO 6100

H: 0.057"

W: 0.110"

Our largest wire that gives an almost scalloped feel.

\*Also available in Stainless Steel on Master Built guitars only.



## SELECT A PICKUP OPTION

**Hand-Wound:** True to Fender history prior to 1965, hand-wound or “scatter-wound” pickups are distinctly unique in character. Each pickup has its own subtle nuances and personalized character which is what made the original Fender pickups so sought after and prized.

**Machine Wound:** Each pickup is consistent and even in winds making each one sound and respond relatively the same. Though most of the Custom Shop pickups are hand-wound, some players prefer the consistency of machine-wound pickups, so we are happy to offer both options.



# STRATOCASTER PICKUPS



## '50S STRAT

Crafted to faithfully replicate the cutting tones reminiscent of 1950s Stratocaster® guitars. Alnico 5 magnets, vintage stagger and formvar wire.



## FAT '50S STRAT

1950s Stratocaster sound you know and love. Hot-rodded wiring design delivers enhanced bass response and an extra shot of 21st-century attitude.



## '60S STRAT

Classic 1960s design with alnico 2 magnets, formvar wire and a vintage stagger. Strat sound with glistening highs and warm punchy lows.



## TEXAS SPECIAL™ STRAT

Characterized by their midrange chirp, crystalline highs and tight bass, Fender Texas Special™ Strat pickups feature an overwound single-coil construction that produces big Texas-blues tone.



## DUAL-MAG STRAT

Vintage style calibrated pickup set with unbeveled alnico 5 magnets on the bass side and beveled alnico 2 magnets on the treble. The two magnet types create balance and consistency in tone and allow for improved clarity string to string.



## EL DIABLO STRAT

Overwound and dipped in the special sauce for a big open sound. Slightly hotter than the Ancho Poblanos with calibrated alnico 5 pickups with custom low G (middle and neck) and flush with high D (bridge) pole pieces.



## ANCHO POBLANO STRAT

Simmered in a secret Custom Shop sauce and then individually calibrated from neck to bridge. Uniquely overwound by hand for a wide range of high-output tones—from blistering-hot output to sizzling vintage warmth—with plenty of tonal flexibility.



## VINTAGE NOISELESS™ STRAT

Produce all the brilliant clarity, definition and harmonic attributes of vintage single-coil Strat tone without the hum.



## TOMATILLO STRAT

Cousins to the Ancho Poblanos, dipped in the same secret sauce. Alnico 2 magnets will simulate what an older alnico 5 might sound like today for a sweeter more flavorful tone.

# TELECASTER PICKUPS



## '51 TELE/NOCASTER

Created with the original design in mind to accurately mimic the twang and shimmer of the originals. These period-correct single-coil pickups impart tight low end and clear, balanced midrange.



## '51 LOADED NOCASTER

Extra winds of #43 gauge enamel wire give these pickups fat, juicy tone. Perfect for driving a preamp into gritty overdrive, these high-output pickups burn with vintage-inspired tone, thanks to the bridge pickup's alnico 3 magnets and neck pickup's alnico 5 magnets.



## '56/'57 TELECASTER

An accurate 1:1 recreation of the Tele pickups we constructed during '56/'57. These pickups have all the grunt and snarl of the originals, thanks to the unbeveled, staggered alnico 5 magnets and enamel-coated wire.



## '63 TELE

A true replication of the original '63 Tele Pickups with all the bite and warmth to spare. Alnico 2 Magnets, vintage stagger and enamel wire.



## '67 TELE

Lower output Tele pickups with Grey bobbins and copper baseplate with a vintage stagger, alnico 5 magnets and enamel wire for crystal clear Tele twang.



## TWISTED TELE

High-output Telecaster guitar tone with a dash of sparkling Stratocaster® guitar character.

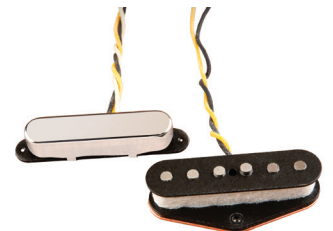

## TEXAS SPECIAL TELE

Fender Custom Shop Texas Special Tele pickups are built to produce blistering hot output, along with noticeable presence and midrange.

43

# BASS PICKUPS



## '64 JAZZ BASS

These vintage-style pickups produce warm, clear and articulate tone, with great low-end definition, up-front midrange punch and singing high end.



## '75 JAZZ BASS

Vintage bobbin construction, Alnico 5 magnets, flush mounted pole pieces and enamel wire provide warm tones, enhanced dynamics and even string response.



## NOISELESS JAZZ BASS

Fender Noiseless Jazz Bass pickups produce all the brilliant clarity, definition and harmonic attributes of a vintage Jazz Bass without the hum.



## HAND WOUND P-BASS

Alnico 5 magnets and enamel wire, hand-wound just like we did in the '50s and '60s. The most iconic bass pickup in the world.



# HUMBUCKER PICKUPS

---



## SHAWBUCKER

Full of multi-dimensional tone with well-defined overtones, this open-coil pickup complements and balances your guitar's natural voice while playing well with other pickup designs.



## CuNiFe WIDE RANGE

The look of the famous Fender pickup design of the early 1970s with period correct magnets, as used on original-era Telecaster Thinline, Telecaster Custom and Telecaster Deluxe models.

# P-90 PICKUPS

---



## CSP-90

CSP-90 This classic design sings with pure Fender tone, bringing clear articulation to every note you play, from delicately nuanced cleans to snarling, spitting means.





## SELECT A WIRING OPTION



# STRATOCASTER WIRING

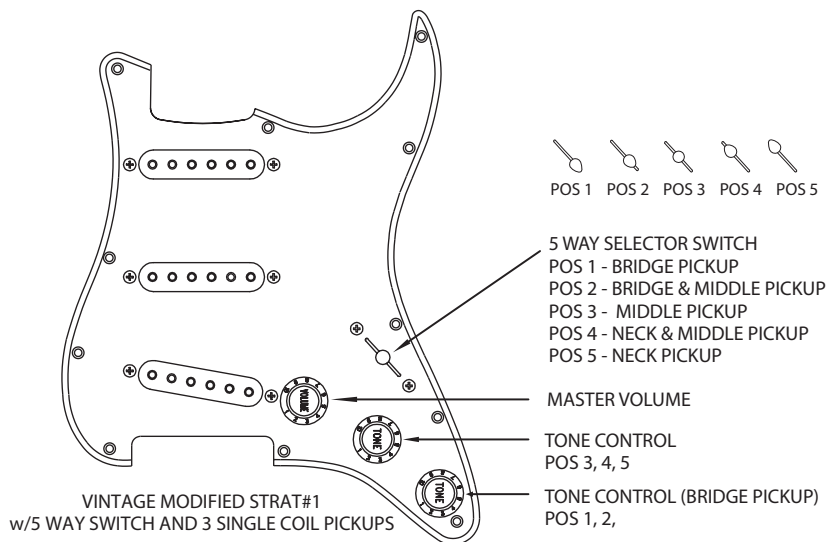
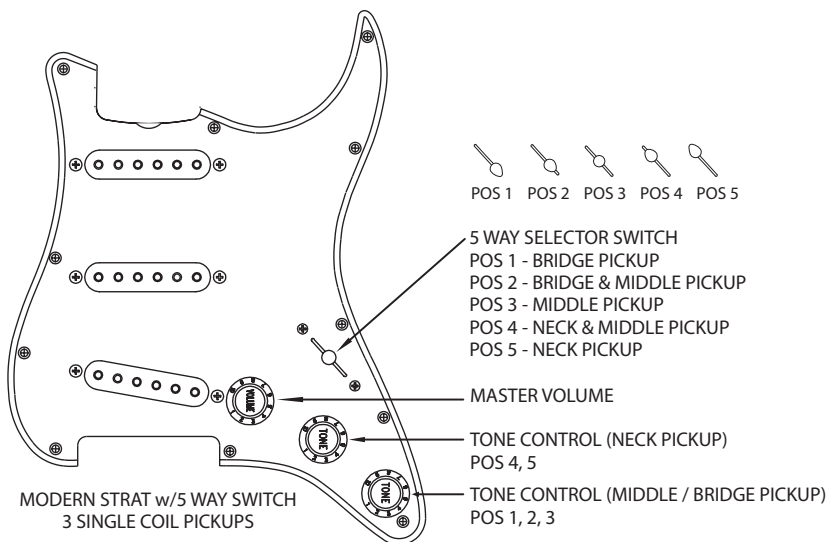
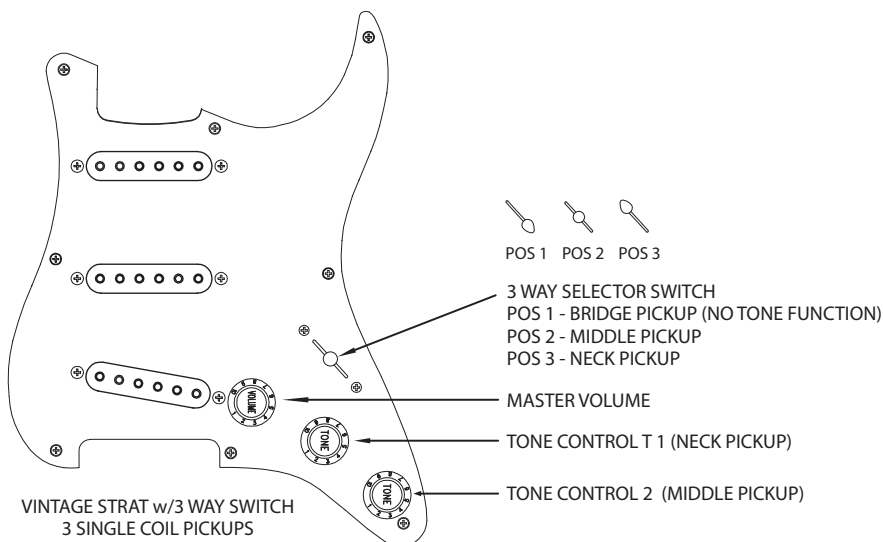

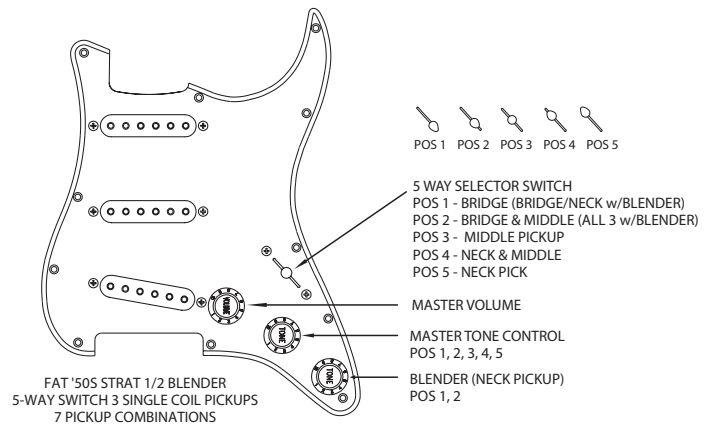
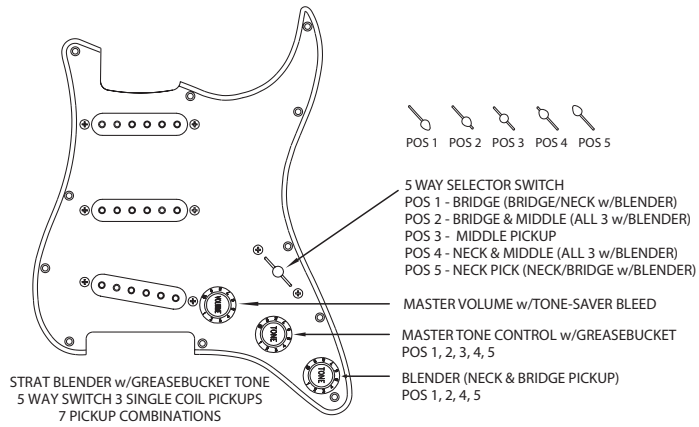
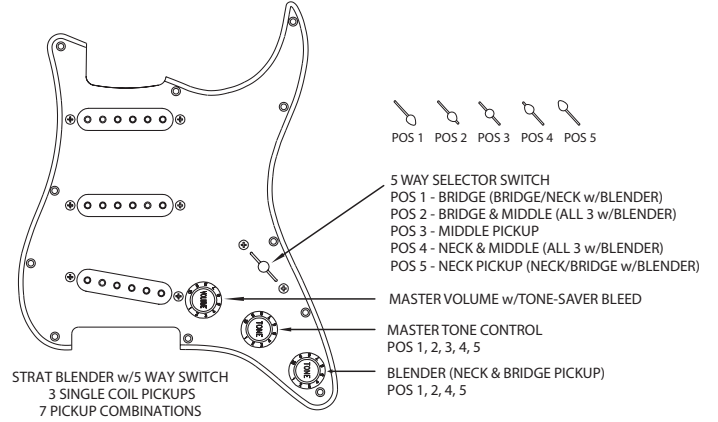
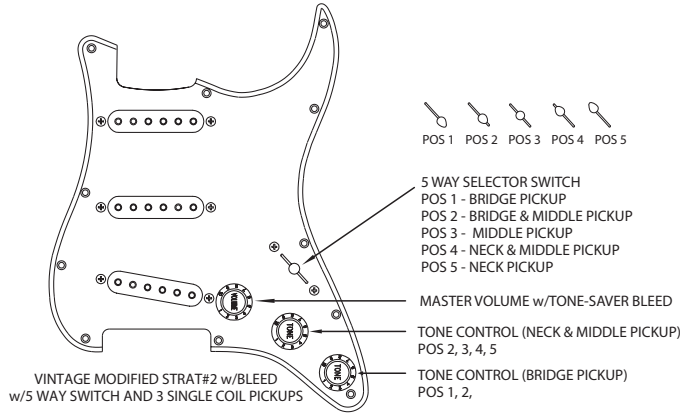



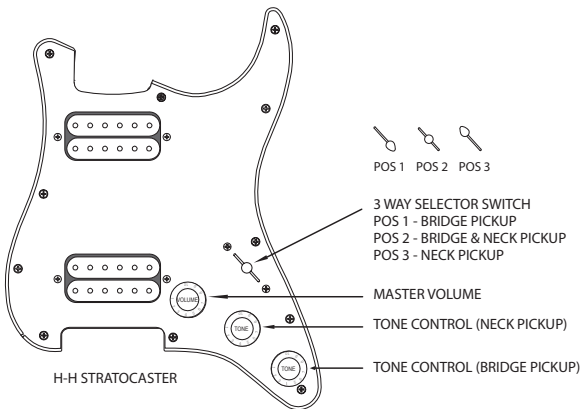
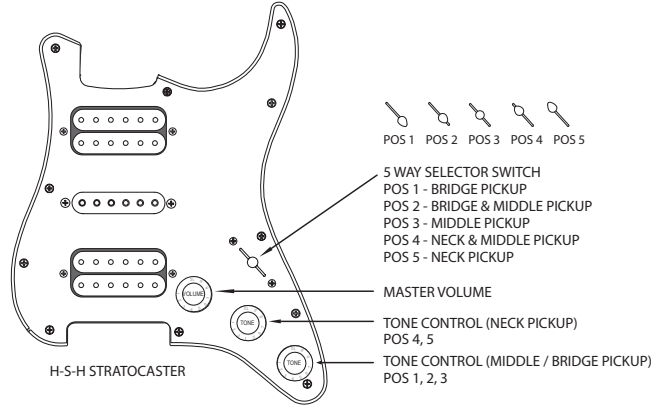
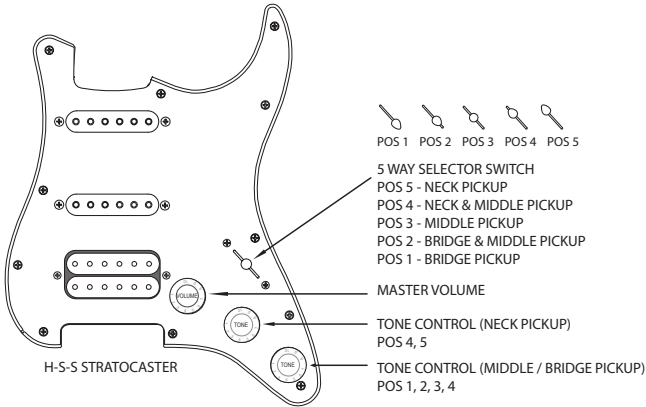

# TELECASTER WIRING

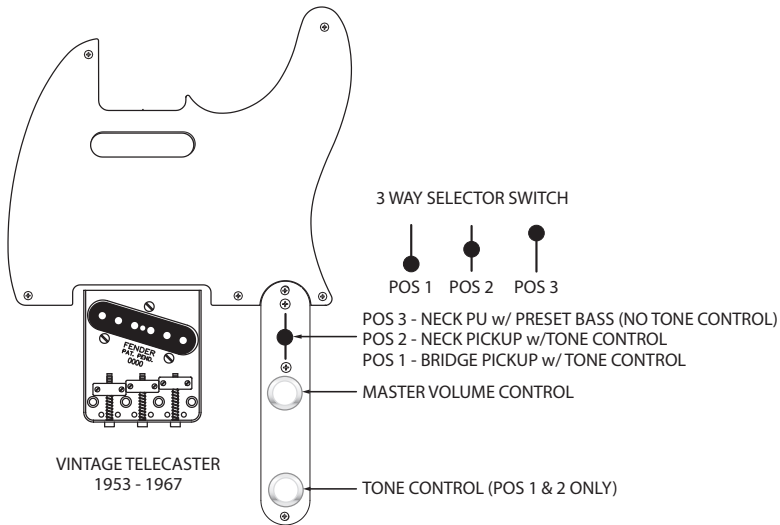
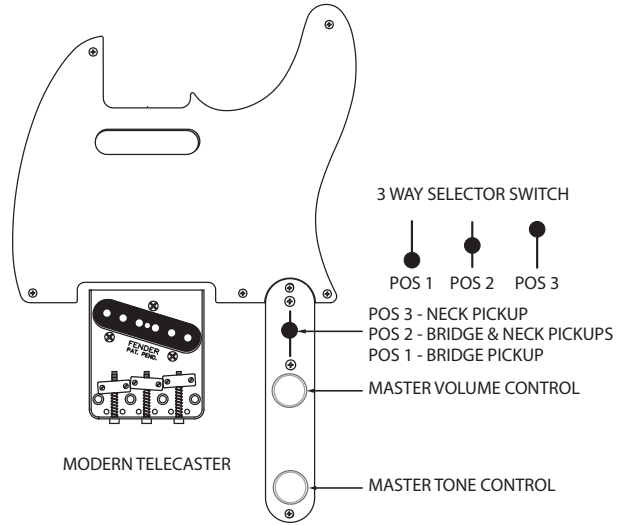
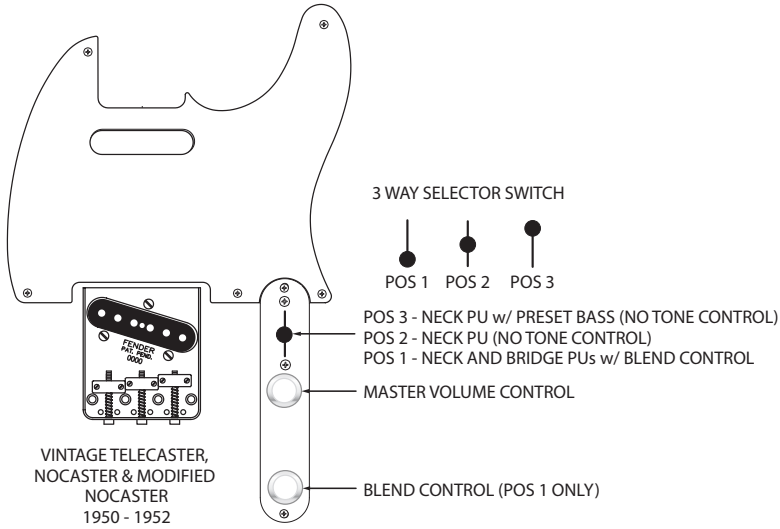



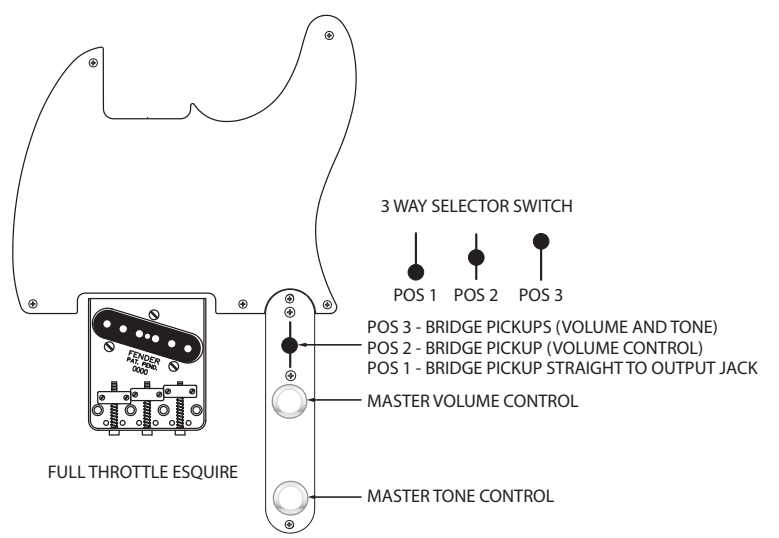
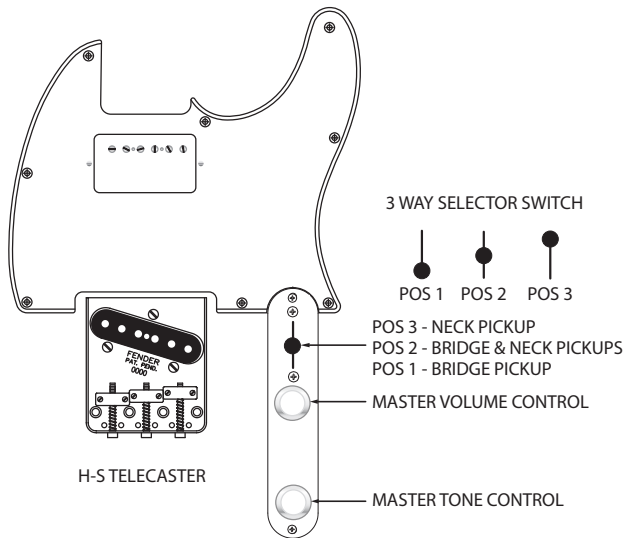
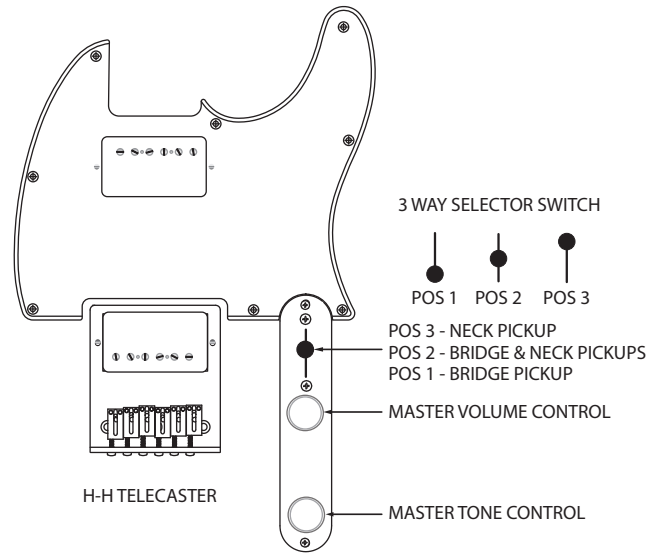
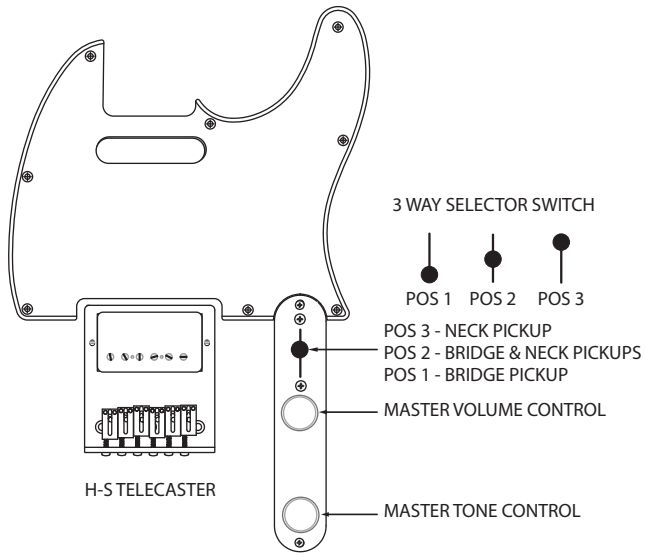

# PRECISION BASS WIRING

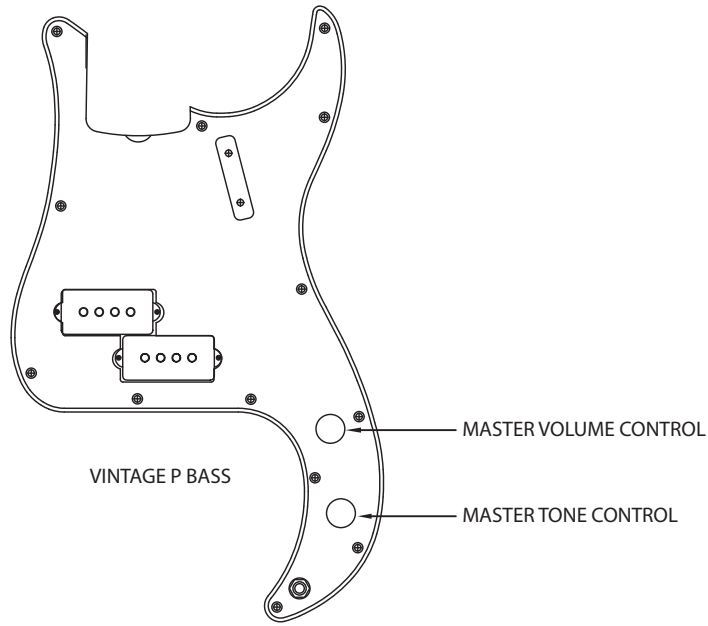

# JAZZ BASS WIRING

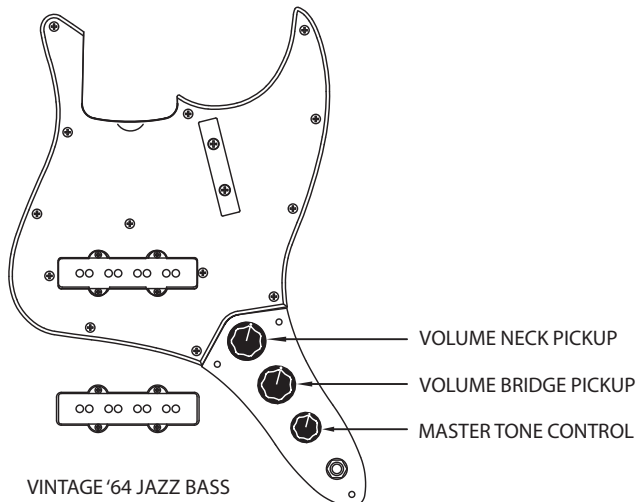
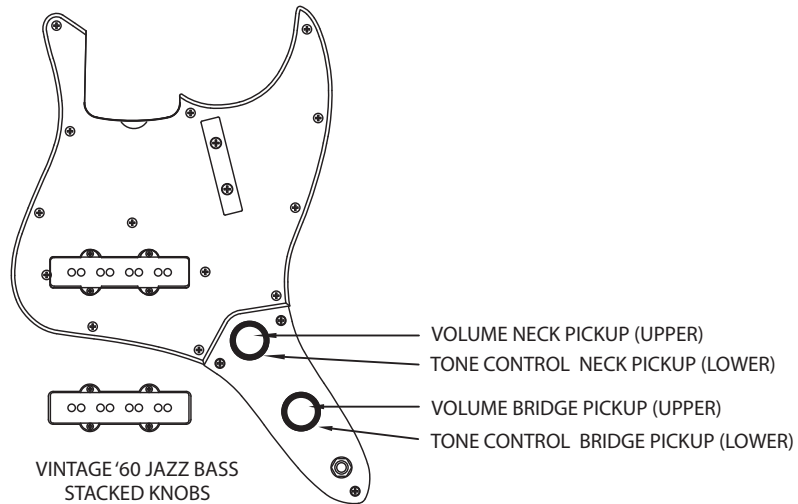



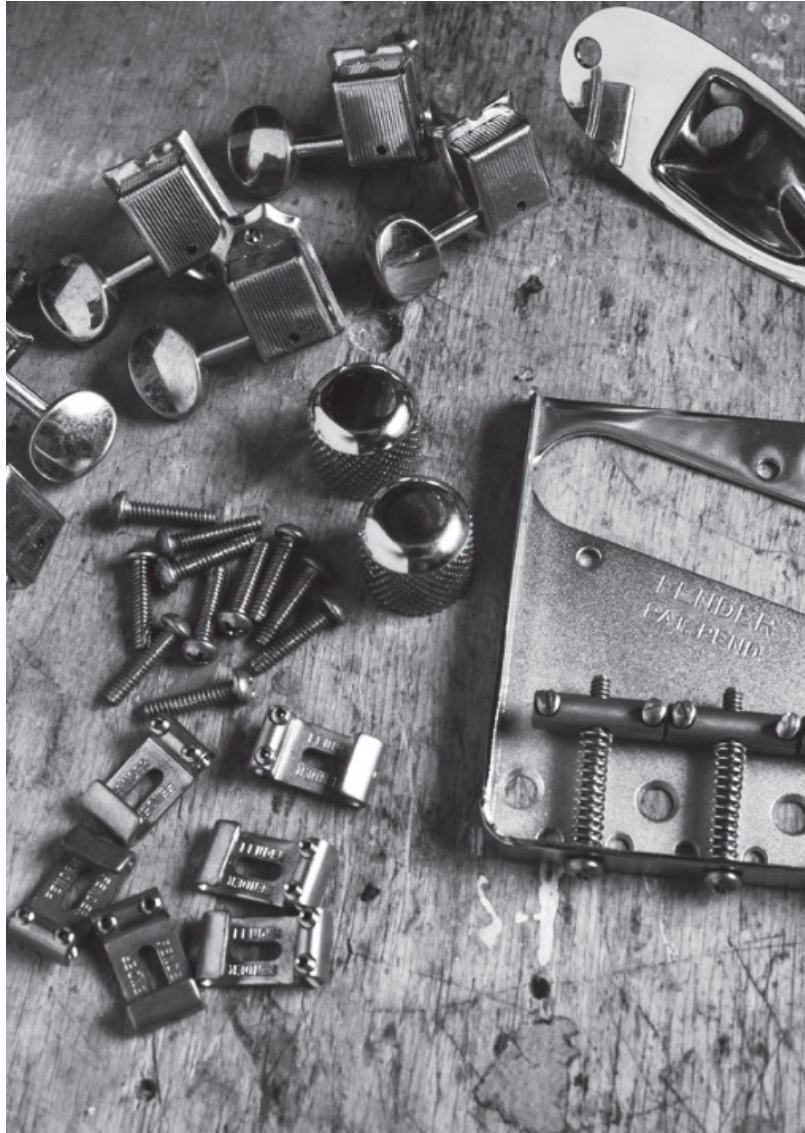

SELECT  
HARDWARE OPTIONS

# STRATOCASTER BRIDGES

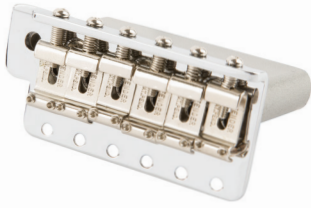

## VINTAGE SYNCHRONIZED TREMOLO

Original Stratocaster tremolo made using original die-cast moulds and punch presses.

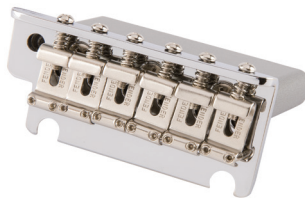

## 2-POINT CLASSIC PLAYER TREMOLO

Polished steel two-point synchronized tremolo bridge assembly.



## 2-POINT CUSTOM CLASSIC TREMOLO

Polished steel two-point synchronized tremolo bridge assembly with polished-steel block saddles.

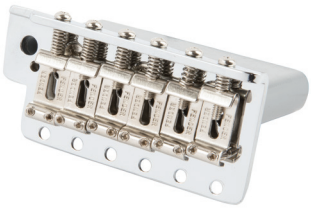

## RSD STRAT TREMOLO

Vintage style with improved pivot geometry, plating tolerances, string spacing and arm tension adjustment.

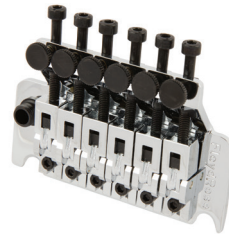

## FLOYD ROSE® ORIGINAL

Double-locking tremolo bridge, recessed for pick hand comfort providing laser-accurate intonation and ultra-stable tuning when combined with the Floyd Rose R3 locking nut.

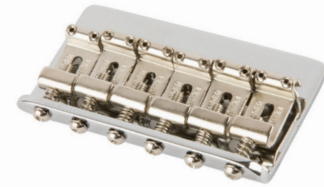

## VINTAGE HARD-TAIL

Original hard-tail Strat bridge made using original die cast moulds and punch presses.

# TELECASTER BRIDGES

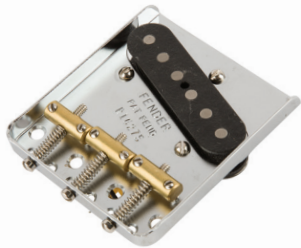

## '51-'53 TELECASTER - BRASS SADDLES

Telecaster ashtray bridge plate with original tooling marks, serial number and 3 brass saddles.

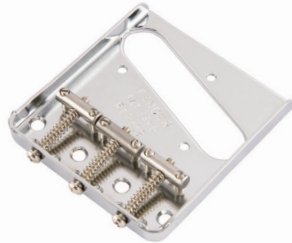

## '54-'57 TELECASTER - STEEL SADDLES

Period correct ashtray bridge plate and steel barrel saddles for bright Tele® twang.

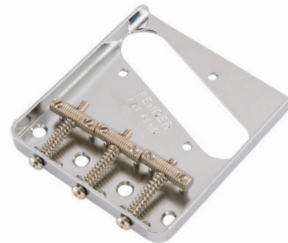

## '60 & UP TELECASTER THREADED SADDLES

Period correct ashtray bridge plate and threaded steel saddles for bright Tele® twang.

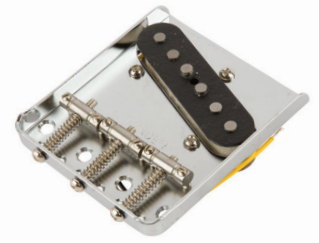

## '67 TELE-SLOTTED STEEL SADDLES

Vintage style ashtray bridge plate with notched steel saddles.

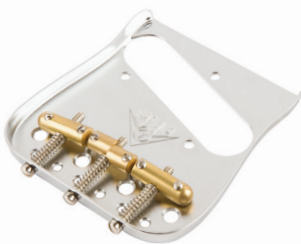

## RSD TELE

Low profile bridge plate, compensated brass saddles with refined look and feel.

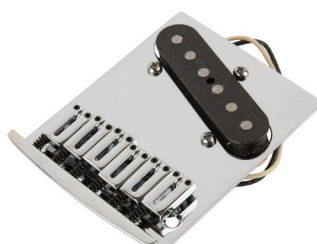

## CUSTOM DELUXE TELE

Modern six-saddle bridge assembly with string-through-body plate, and polished steel saddles.

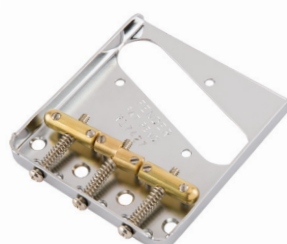

## VINTAGE RSD TELE

Vintage style ashtray bridge plate with compensated RSD Saddles.



# BASS BRIDGES

---

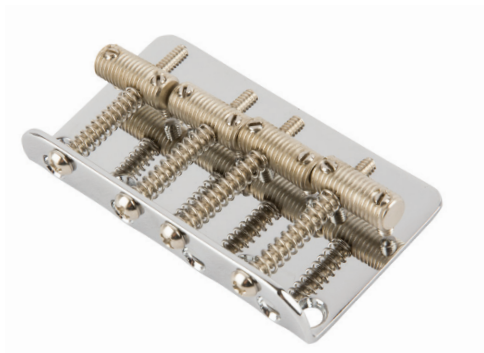

## VINTAGE THREADED SADDLES

Genuine Fender bass bridge assembly with nickel-plated steel bridge plate and four threaded barrel saddles.

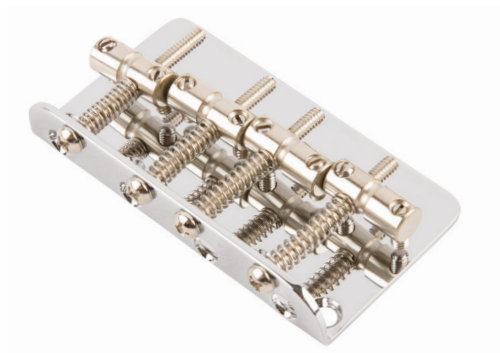

## VINTAGE GROOVE SADDLES

Vintage Fender bass bridge assembly with nickel-plated steel bridge plate and four grooved barrel saddles.

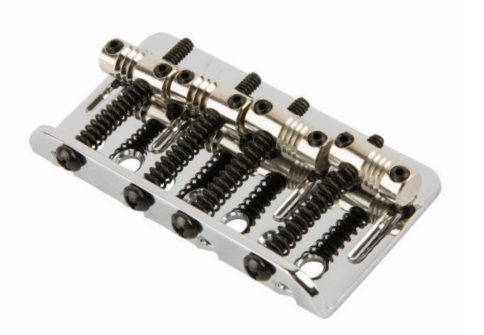

## AMERICAN DELUXE BASS BRIDGE

Chrome plated steel bridge plate with partially threaded stainless steel saddles and string through body or top load option.



## RSD BASS

Hi-Mass Bridge constructed from a solid brass billet with threaded steel saddles.

# JAZZMASTER/JAGUAR BRIDGES

---



## RSD J-BRIDGE

Two movable brass saddles bolted to a cold rolled steel base provides an articulate tone with more punch, attack and continuity than its predecessor. The J-Bridge lets the sound of the guitar ring through and gives a stronger primary note.

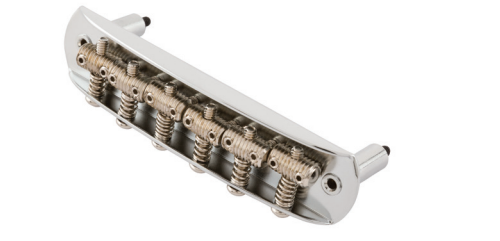

## VINTAGE JAZZ/JAG

Nickel-plated bridge assembly with 6 adjustable threaded saddles.

# TUNING MACHINES



**SCHALLER F**



**MODERN AMERICAN STANDARD**



**MODERN LOCKING**



**VINTAGE LOCKING**



**VINTAGE STYLE**

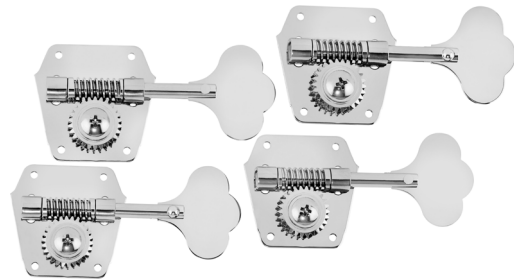

**VINTAGE STYLE BASS**

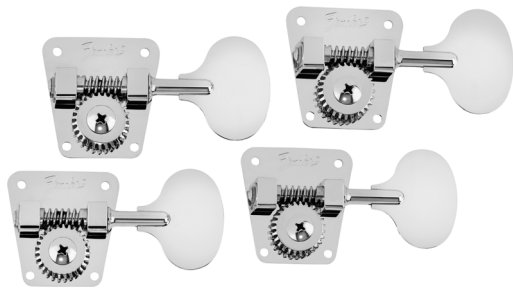

**VINTAGE STYLE BASS "LOLLIPOP"**



**MODERN BASS**



# PICKGUARDS

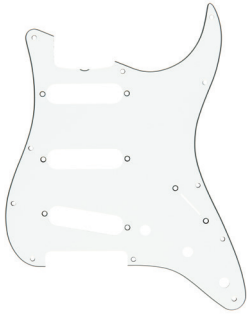

3-PLY WHITE

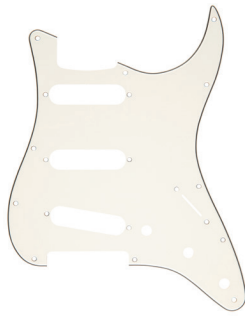

3-PLY EGGSHELL

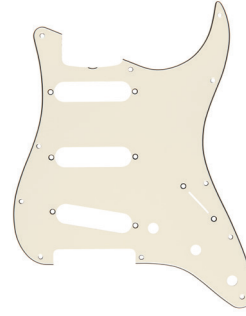

3-PLY PARCHMENT



3-PLY MINT GREEN



ANODIZED GOLD



4-PLY BROWN SHELL



BLACK



BLACK PEARLOID



WHITE PEARLOID

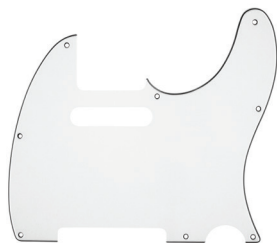

3-PLY WHITE

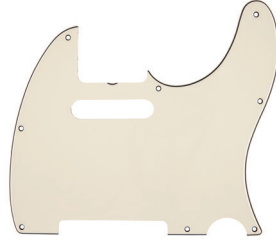

3-PLY PARCHMENT



1-PLY PARCHMENT



3-PLY BLACK



BLACK PHENOLIC

# SWITCH TIPS, CONTROL KNOBS, AND PICKUP COVERS

## SWITCH TIPS



WHITE



EGGSHELL



AGED WHITE



VINTAGE WHITE



BLACK

## CONTROL KNOBS



WHITE



EGGSHELL



AGED WHITE



VINTAGE WHITE



BLACK

## PICKUP COVERS



WHITE



EGGSHELL

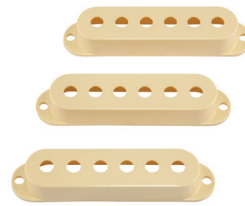

AGED WHITE

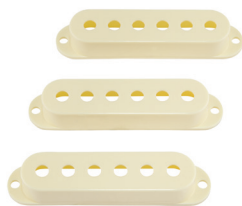

VINTAGE WHITE



BLACK



# DESIGN GUIDE ORDER FORM

## BUILD LEVEL (SELECT ONE)

- MASTERBUILT  
SELECT BUILDER \_\_\_\_\_
- ADD PREMIUM BUILDER
- CUSTOM-BUILT

## BASE MODEL

### STRATOCASTER (START AT PG 16)

- 1955 STRATOCASTER (ASH)
- 1956 STRATOCASTER (ALDER)
- OTHER 1950'S STRATOCASTER (ALDER) \_\_\_\_\_
- 1960 STRATOCASTER (ALDER)
- 1963 STRATOCASTER (ALDER)
- 1965 STRATOCASTER (ALDER)
- 1966 STRATOCASTER (ALDER/LARGE HEADSTOCK)
- 1969 STRATOCASTER (ALDER/LARGE HEADSTOCK)
- OTHER 1960'S STRATOCASTER (ALDER) \_\_\_\_\_
- AMERICAN CUSTOM STRATOCASTER (ALDER)
- ANVIL FLIGHT CASE OPTION (STRAT)

### NOCASTER/TELECASTER/ESQUIRE (START AT PG 18)

- 1951 NOCASTER (ASH)
- 1952 TELECASTER (ASH)
- OTHER 1950'S TELECASTER (ASH) \_\_\_\_\_
- 1960 TELECASTER (ALDER)
- 1960 TELECASTER CUSTOM (ALDER)
- 1963 TELECASTER (ALDER)
- 1967 TELECASTER (ALDER)
- OTHER 1960'S TELECASTER (ALDER) \_\_\_\_\_
- 1959 ESQUIRE (ASH)
- OTHER YEAR ESQUIRE \_\_\_\_\_ (THRU '69)
- '50S THINLINE TELECASTER
- AMERICAN CUSTOM TELECASTER (ASH)
- ANVIL FLIGHT CASE OPTION (TELE)

### JAZZMASTER/JAGUAR/BASS VI (START AT PG 22)

- 1962 JAZZMASTER (ALDER)
- OTHER YEAR JAZZMASTER (ALDER) \_\_\_\_\_ (THRU '66)
- 1962 JAGUAR (ASH)
- OTHER YEAR JAGUAR (ALDER) \_\_\_\_\_ (THRU '65)
- BASS VI (ALDER)

### FENDER BASS (START AT PG 20)

- 1955 PRECISION BASS (ASH)
- 1959 PRECISION BASS (ALDER)
- 1960 PRECISION BASS (ALDER)
- OTHER YEAR PRECISION BASS (ALDER) \_\_\_\_\_ (THRU '69)
- 1964 JAZZ BASS (ALDER)
- 1975 JAZZ BASS (ALDER)
- OTHER YEAR JAZZ BASS \_\_\_\_\_ (THRU '74)

## AGING STYLE (START AT PG 24)

- NOS (NEW OLD STOCK)
- TIME CAPSULE (FLASH-COAT NOS/CC HDW)
- CLOSET CLASSIC

- CLOSET CLASSIC/NOS HDW
- DLX CLOSET CLASSIC
- JOURNEYMAN RELIC®
- JOURNEYMAN RELIC/CLOSET CLASSIC HDW
- RELIC
- RELIC/CLOSET CLASSIC HDW
- HEAVY RELIC
- HEAVY RELIC/CLOSET CLASSIC HDW

## CUSTOM OPTIONS

### CONSTRUCTION

- LEFT HANDED
- CHAMBERED BODY
- HOLLOW BODY W/ F-HOLE (WITH ARM CONTOUR)
- BOUND BODY TOP (NO ARM CONTOUR)
- BOUND BODY TOP & BACK (NO CONTOURS)
- BOUND FINGERBOARD
- BOUND HEADSTOCK
- REVERSE HEADSTOCK
- CONTOURED NECK HEEL
- REVERSE ANGLE BRIDGE PICKUP ROUT

### BODY WOOD

- BASE MODEL BODY WOOD
- ALDER
- ASH
- EASTERN WHITE PINE
- OKOUME
- FIJI MAHOGANY
- ROASTED ALDER
- ROASTED ASH
- ROASTED PINE
- SORT FOR LIGHT WEIGHT BODY WOOD
- OTHER BODY WOOD
- BODY WOOD/EXOTIC TOP
- FLAME MAPLE TOP 2A
- QUILTED MAPLE TOP 2A
- SPALTED MAPLE TOP
- MAPLE BURL TOP
- BUCKEYE BURL TOP
- ZIRICOTE TOP
- COCOBOLLO TOP
- FIGURED KOA TOP 4A
- OTHER EXOTIC TOP

### BODY COLOR (SELECT FROM PAGE 32)

- SINGLE COLOR # \_\_\_\_\_
- COLOR OVER COLOR # \_\_\_\_\_ O # \_\_\_\_\_
- SPARKLE COLOR
- PINK PAISLEY (TOP)
- PINK PAISLEY (TOP & BACK)
- BLACK PAISLEY (TOP)
- BLACK PAISLEY (TOP & BACK)
- BLUE FLOWER (TOP)
- BLUE FLOWER (TOP & BACK)

\*For base model specifications see page 17

**CUSTOM OPTIONS (CONTINUED)****BODY FINISH**

- BASE MODEL FINISH
- NITRO LACQUER
- NITRO LACQUER / WLS UNDERCOAT
- FLASH COAT LACQUER
- URETHANE

**NECK WOOD**

- BASE MODEL NECK WOOD (FLAT SAWN MAPLE)
- RIFT SAWN MAPLE
- QUARTERSAWN MAPLE
- FLAME MAPLE 2A
- FLAME QUARTERSAWN MAPLE 2A
- FLAME MAPLE 3A
- BIRDSEYE MAPLE 2A
- BIRDSEYE MAPLE 3A
- ROASTED BIRDSEYE MAPLE 3A
- ROASTED RIFT SAWN MAPLE
- ROASTED QUARTERSAWN MAPLE
- ROASTED FLAME MAPLE 3A
- INDIAN ROSEWOOD
- OTHER NECK WOOD \_\_\_\_\_

**NECK TINT**

- NO TINT
- LIGHT TINT
- MEDIUM TINT
- DARK TINT

**NECK FINISH**

- BASE MODEL FINISH
- NITRO LACQUER
- FLASH COAT LACQUER
- URETHANE
- SATIN URETHANE
- SATIN LACQUER
- MATCHING PAINTED HEADCAP

**NECK SHAPE**

- BASE MODEL NECK SHAPE\*
- CUSTOM NECK SHAPE # \_\_\_\_\_ (START AT PAGE 35)

**FINGERBOARD WOOD**

- BASE MODEL FINGERBOARD WOOD
- 1-PIECE MAPLE NECK
- ROUND-LAM MAPLE
- SLAB ROSEWOOD
- ROUND-LAM ROSEWOOD
- SORT FOR DARK ROSEWOOD
- AFRICAN BLACKWOOD
- EBONY

**FINGERBOARD RADIUS**

- BASE MODEL FINGERBOARD RADIUS
- 7.25" RADIUS
- 9.5" RADIUS
- 12.00" RADIUS
- 7.25" TO 9.5" VINTAGE COMPOUND RADIUS
- 7.25" TO 12" COMPOUND RADIUS
- 9.5" TO 12" COMPOUND RADIUS

- 9.5" TO 14" COMPOUND RADIUS
- 9.5" TO 16" COMPOUND RADIUS (BASS ONLY)
- SCALLOPED FINGERBOARD

**WIDTH AT NUT**

- BASE MODEL WIDTH AT NUT
- 1.650"
- 1.685"
- 1.6875"

**NUT MATERIAL**

- BASE MODEL NUT MATERIAL
- MICARTA
- BONE
- GRAPHITE
- LSR ROLLERNUT

**NUMBER OF FRETS**

- BASE MODEL NUMBER OF FRETS
- 22 FRETS (STRAT/TELE)

**FRET WIRE**

- BASE MODEL FRET WIRE
- VINTAGE
- MEDIUM VINTAGE 47095
- NARROW TALL 6105
- MEDIUM JUMBO 6150
- JUMBO 6100
- OTHER FRET WIRE \_\_\_\_\_

**POSITION & SIDE MARKERS**

- BASE MODEL DOT MATERIAL
- BLACK
- WHITE
- VINTAGE CLAY
- MOP WHITE
- BLACK POLY PEARL BLOCK INLAY
- WHITE POLY PEARL BLOCK INLAY
- ABALONE
- WHITE MOP BLOCK INLAY

**12<sup>TH</sup> FRET DOT SPACING**

- BASE MODEL DOT SPACING
- WIDE 12TH FRET DOT SPACING
- NARROW 12TH FRET DOT SPACING

**TRUSS ROD**

- BASE MODEL TRUSS ROD
- BI-FLEX™ (STRAT/TELE HEADSTOCK ADJUST)

**HARDWARE COLOR**

- BASE MODEL HARDWARE COLOR (NICKEL/CHROME)
- GOLD

**NECK PLATE**

- BASE MODEL NECK PLATE (R SERIAL)
- V-LOGO NECK PLATE
- F-LOGO NECK PLATE
- F-LOGO NECK PLATE (CONTOURED HEEL)



**BRIDGE**

- BASE MODEL BRIDGE

**STRATOCASTER BRIDGE**

- AM VINTAGE SYNCHRONIZED TREMOLO  
 CUSTOM SHOP VINTAGE STRAT TREMOLO  
 2-POINT CLASSIC PLAYER TREMOLO  
 2-POINT CUSTOM CLASSIC TREMOLO  
 RSD STRAT TREMOLO  
 VINTAGE HARD-TAIL  
 CUSTOM CLASSIC HARD-TAIL  
 FLOYD ROSE® DOUBLE LOCKING

**TELECASTER BRIDGE**

- '51 - '53 TELE - BRASS SADDLES  
 '54 - '57 TELE - STEEL SADDLES  
 '58 - '63 TELE - THREADED SADDLES  
 '64 - '66 TELE - THREADED SADDLES  
 '67 TELE - SLOTTED STEEL SADDLES  
 CUSTOM DELUXE TELE BRIDGE  
 RSD TELE BRIDGE  
 RSD HARDTAIL (SAWED OFF TELE)  
 BIGSBY® B-5 VIBRATO TAILPIECE

**PRECISION/JAZZ BASS**

- VINTAGE 2-SADDLE BRIDGE  
 VINTAGE THREADED SADDLES BRIDGE  
 VINTAGE GROOVE SADDLES BRIDGE  
 AMERICAN DELUXE  
 RSD BASS BRIDGE  
 AMERICAN STANDARD "HIGH MASS"  
 FENDER "HIGH MASS"

**JAZZMASTER/JAGUAR**

- RSD J-BRIDGE

**TUNING MACHINES**

- BASE MODEL TUNING MACHINES  
 VINTAGE STYLE  
 VINTAGE STAGGERED  
 VINTAGE LOCKING  
 SPERZEL DELUXE  
 SPERZEL DELUXE W/ PEARL BUTTONS  
 SPERZEL TRIM-LOK™  
 FENDER/SCHALLER "F"  
 OTHER \_\_\_\_\_

**PICKGUARD**

- BASE MODEL PICKGUARD  
 1-PLY WHITE  
 1-PLY EGGSHELL  
 1-PLY PARCHMENT  
 1-PLY BLACK  
 1-PLY BLACK PHENOLIC LAMINATE  
 3-PLY WHITE  
 3-PLY EGGSHELL  
 3-PLY PARCHMENT  
 3-PLY MINT GREEN  
 3-PLY BLACK  
 4-PLY BROWN SHELL  
 BLACK PEARLOID  
 WHITE PEARLOID  
 ANODIZED GOLD  
 OTHER \_\_\_\_\_

**CONTROL KNOBS**

- BASE MODEL CONTROL KNOBS

**STRATOCASTER KNOBS**

- WHITE  
 EGGSHELL  
 PARCHMENT  
 VINTAGE WHITE  
 BLACK

**TELECASTER/PRECISION BASS KNOBS**

- VINTAGE KNURLED  
 ALUMINUM KNURLED

**STRATOCASTER PICKUP COVERS**

- BASE MODEL COVERS  
 WHITE  
 EGGSHELL WHITE  
 PARCHMENT WHITE  
 VINTAGE WHITE  
 BLACK  
 LIPSTICK COVERS (EACH)

**WIRING**

- BASE MODEL WIRING

**STRATOCASTER WIRING**

- VINTAGE STRAT  
 MODERN STRAT  
 VINTAGE MODIFIED #1  
 VINTAGE MODIFIED #2 W/ TONE-SAVER  
 STRAT BLENDER  
 STRAT BLENDER W/ GREASEBUCKET  
 FAT 50'S HOOKUP  
 1/2 BLENDER WITH TONE SAVER TREBLE BLEED  
 1/2 BLENDER WITH GREASE BUCKET 2  
 FAT 50'S HOOKUP W/ HALF BLENDER  
 FAT 50'S HOOKUP W/ GREASEBUCKET  
 H-S-S POMO STRAT 250/500  
 H-S-S CONFIGURATION  
 H-S-H CONFIGURATION  
 H-H CONFIGURATION  
 OTHER STRAT WIRING \_\_\_\_\_

**TELECASTER/ESQUIRE WIRING**

- VINTAGE ESQUIRE (1-PICKUP)  
 FULL THROTTLE ESQUIRE (1-PICKUP)  
 '51 NOCASTER ('50-'52 BLACKGUARD)  
 '51 MODIFIED NOCASTER  
 '53-'59 VINTAGE TELE  
 MODERN TELE  
 MODERN TELE W/ GREASEBUCKET  
 MODERN TELE W/ 4-WAY SWITCH  
 MODERN TELE WITH 4-WAY  
 FAT '50S TELE  
 FAT 50S DUAL P90 TELE  
 FAT 50S DUAL P90 TELE W/ ANGLED SWITCH  
 NASHVILLE TELE W/ BLENDER  
 NASHVILLE TELE (3-PICKUP TELE)  
 H-S TELE DUAL-STACK 250/500  
 H-S TELE CABALLO 250/500  
 H-H TELE  
 OTHER TELE WIRING \_\_\_\_\_  
 FULL THROTTLE ESQUIRE (1-PICKUP)

**JAZZ BASS® WIRING**

- VINTAGE JAZZ BASS W/ CONCENTRIC KNOBS  
 VINTAGE JAZZ BASS VOL, VOL, TONE

**MISCELLANEOUS ELECTRONICS**

- 3-WAY SWITCH (STRAT)
- REVERSE TELE CONTROL PLATE
- TONE-SAVER TREBLE BLEED
- GREASEBUCKET TONE CONTROL
- TBX TONE CONTROL
- NO-LOAD TONE CONTROL
- S-1 SWITCH
- S-1 FUNCTION \_\_\_\_\_

**PICKUPS**

**PICKUPS** **N M B**

BASE MODEL PICKUPS\*

RWRP MIDDLE PICKUP

**STRATOCASTER PICKUPS (PRICE PER PICKUP)**

'54 STRAT

'50S STRAT

FAT '50S STRAT

'60S STRAT

FAT '60S STRAT

'58 STRAT

'59 STRAT

'65 STRAT

'66 STRAT

'69 STRAT

TEXAS SPECIAL STRAT

**HAND-WOUND STRAT® PICKUPS (PRICE PER PICKUP)**

ADD JOSEFINA MASTER WOUND UPGRADE

HW '50S STRAT

HW FAT '50S STRAT

HW '55 STRAT

HW '56 STRAT

HW '57 STRAT

HW '59 STRAT

HW '60 STRAT

HW FAT '60 STRAT

HW '60/'63 STRAT

HW '64 STRAT

HW FAT '64 STRAT

HW '65 STRAT

HW '66 STRAT

HW '69 STRAT

HW TEXAS SPECIAL STRAT

HW TROPOSPHERE™ STRAT

HW MASTER DESIGN LTD STRAT

HW MASTER DESIGN BONE TONE

HW DUAL-MAG STRAT

HW DUAL-MAG II STRAT

HW EL DIABLO STRAT

HW TOMATILLO STRAT

HW ANCHO POBLANO STRAT

**OTHER STRAT PICKUPS**

FENDER LACE SENSOR

FENDER VINTAGE NOISELESS

DUNCAN® SLDS-1 HOT RAILS™

DUNCAN SSL-3 HOT STRAT

DUNCAN LI'L SCREAMIN' DEMON™

DUNCAN SLS-1 LIPSTICK TUBE

**TELECASTER PICKUPS (PRICE PER PICKUP)**

ORIGINAL BLACKGUARD TELE (OBG) - -

'51 TELECASTER/NOCASTER  -

'56/'57 TELE  -

'63 TELE  -

'64 TELE  -

'67 TELE  -

TEXAS SPECIAL TELE  -

TWISTED TELE  -

**HAND-WOUND TELE® PICKUPS (PRICE PER PICKUP)**

ADD JOSEFINA MASTER WOUND UPGRADE  -

HW ORIGINAL BLACKGUARD (OBG) - -

HW '50/'51 BLACKGUARD  -

HW '50/'51 CRUSHED BLACKGUARD - -

HW '51 NOCASTER  -

HW '51 LOADED NOCASTER  -

HW '55/'56 TELE  -

HW '58 TELE  -

HW '63 TELE  -

HW '64 TELE  -

HW '67 TELE  -

HW TWISTED TELE  -

HW TEXAS SPECIAL TELE  -

HW RED HOT TELE  -

H/W TOMATILLO TELE  -

**OTHER TELE PICKUPS**

FENDER VINTAGE NOISELESS  -

DUNCAN FIVE-TWO TELE  -

DUNCAN QUARTER POUND  -

DUNCAN LITTLE '59™  -

\*For base model specifications see page 17



<b>HUMBUCKING/P90 PICKUPS</b>	<b>N</b>	<b>M</b>	<b>B</b>
FENDER SHAWBUCKER	<input type="checkbox"/>	-	<input type="checkbox"/>
EVH® WOLFGANG HUMBUCKER	<input type="checkbox"/>		<input type="checkbox"/>
EVH FRANKENSTEIN HUMBUCKER	<input type="checkbox"/>	-	<input type="checkbox"/>
DUNCAN SH-1 59	<input type="checkbox"/>	-	-
DUNCAN SH-55 SETH LOVER	-	-	<input type="checkbox"/>
DUNCAN SH-4 JB BRIDGE	<input type="checkbox"/>		<input type="checkbox"/>
DUNCAN TB-4 TREMBUCKER™	<input type="checkbox"/>	-	<input type="checkbox"/>
DUNCAN SH-PG1 PEARLY GATES™	<input type="checkbox"/>	-	<input type="checkbox"/>
DUNCAN ANTIQUITY HUMBUCKER	<input type="checkbox"/>	-	<input type="checkbox"/>
DUNCAN APH-1 ALNICO II PRO™	<input type="checkbox"/>	-	<input type="checkbox"/>
DUNCAN TBAPH-1 ALNICO II PRO TREMBUCKER	<input type="checkbox"/>	-	<input type="checkbox"/>
DUNCAN SCREAMIN' DEMON	<input type="checkbox"/>	-	<input type="checkbox"/>
DUNCAN SH-8 INVADER	<input type="checkbox"/>	-	<input type="checkbox"/>
TV JONES® CLASSIC (TELE ONLY)	<input type="checkbox"/>	-	<input type="checkbox"/>
TV JONES CLASSIC PLUS (TELE ONLY)	<input type="checkbox"/>	-	<input type="checkbox"/>
TV JONES POWER 'TRON (TELE ONLY)	<input type="checkbox"/>	-	<input type="checkbox"/>
TV JONES POWER 'TRON PLUS (TELE ONLY)	<input type="checkbox"/>	-	<input type="checkbox"/>
TV JONES SUPER 'TRON (TELE ONLY)	<input type="checkbox"/>	-	<input type="checkbox"/>
TV JONES MAGNA 'TRON (TELE ONLY)	<input type="checkbox"/>	-	<input type="checkbox"/>
P-90	<input type="checkbox"/>	-	<input type="checkbox"/>

<b>BASS PICKUPS</b>	<b>N</b>	<b>M</b>	<b>B</b>
<b>PRECISION BASS PICKUPS</b>			
'55 PRECISION BASS	-	<input type="checkbox"/>	-
'57 PRECISION BASS	-	<input type="checkbox"/>	-
'59 – '62 PRECISION BASS	-	<input type="checkbox"/>	-
'59 – '62 PRECISION BASS (FLAT POLES)	-	<input type="checkbox"/>	-
HW '55 PRECISION BASS	-	<input type="checkbox"/>	-
HW '57 PRECISION BASS	-	<input type="checkbox"/>	-
HW '62 PRECISION BASS	-	<input type="checkbox"/>	-
H/W '65-'70 PRECISION BASS	-	<input type="checkbox"/>	-
<b>JAZZ BASS PICKUPS</b>			
VINTAGE JAZZ BASS	<input type="checkbox"/>	-	<input type="checkbox"/>
'75 JAZZ BASS	<input type="checkbox"/>	-	<input type="checkbox"/>
VINTAGE NOISELESS JAZZ BASS	<input type="checkbox"/>	-	<input type="checkbox"/>
HW VINTAGE JAZZ BASS	<input type="checkbox"/>	-	<input type="checkbox"/>
HW '75 JAZZ BASS	<input type="checkbox"/>	-	<input type="checkbox"/>
<b>JAZZMASTER/JAGUAR/BASS VI PICKUPS</b>			
VINTAGE JAZZMASTER	<input type="checkbox"/>	-	<input type="checkbox"/>
HW VINTAGE JAZZMASTER	<input type="checkbox"/>	-	<input type="checkbox"/>
VINTAGE JAGUAR/BASS VI	<input type="checkbox"/>	-	<input type="checkbox"/>

## PICKUP SPECS

<b>HAND-WOUND</b>	<b>NOMINAL DC RESISTANCE +/- 10%</b>				<b>WIRE</b>	<b>MAGNETS</b>	<b>STAGGER</b>	<b>NOTES</b>
	<b>NECK</b>	<b>MIDDLE</b>	<b>MID-RWRP</b>	<b>BRIDGE</b>				
H/W 50'S STRAT	6.12K	6.12K	6.12K		FORMVAR	ALNICO 5	VINTAGE	CALIBRATED SET
H/W 50'S STRAT				6.39K	FORMVAR	ALNICO 5	CUSTOM LOW G	
H/W FAT 50'S STRAT	6.26K		6.34K	6.48K	FORMVAR	ALNICO 5	VINTAGE	CALIBRATED SET
H/W '55 STRAT	5.60K	5.60K		5.60K	FORMVAR	ALNICO 3	VINTAGE LOW G	
H/W '56 STRAT	5.98K		5.98K	6.22K	FORMVAR	ALNICO 5	CUSTOM LOW G	CALIBRATED SET
H/W '57 STRAT	6.02K		6.02K	6.39K	FORMVAR	ALNICO 5	VINTAGE	CALIBRATED SET
H/W '59 STRAT	5.80K	5.80K		5.80K	FORMVAR	ALNICO 5	VINTAGE	
HW '60'S STRAT	5.83K	5.83K	5.83K	5.83K	FORMVAR	ALNICO 2	VINTAGE	
HW FAT 60'S STRAT	6.64K	6.64K	6.64K	6.64K	FORMVAR	ALNICO 2	VINTAGE	
H/W '60-'63 STRAT	6.20K		6.35K	6.47K	FORMVAR	ALNICO 5	VINTAGE	CALIBRATED SET
H/W '64 STRAT	5.31K		5.56K	5.81K	ENAMEL	ALNICO 5	VINTAGE	CALIBRATED SET
H/W '65 STRAT	6.27K	6.27K	6.27K	6.27K	POLYSOL	ALNICO 5	VINTAGE	
H/W VINT '65 STRAT	5.90K	5.90K	5.90K	5.90K	ENAMEL	ALNICO 5	VINTAGE	
H/W '69 STRAT	5.61K	5.61K	5.61K	5.61K	ENAMEL	ALNICO 5	VINTAGE	
H/W TEXAS SPECIAL STRAT	5.94K		6.27K	6.56K	ENAMEL	ALNICO 5	VINTAGE	CALIBRATED SET
H/W MASTER DESIGN STRAT	6.45K		6.45K		FORMVAR	ALNICO 5	VINTAGE	CALIBRATED SET
H/W MASTER DESIGN STRAT				6.84K	ENAMEL	ALNICO 5	FLUSH	
H/W MASTER DESIGN LTD	7.03K	7.03K	7.03K	7.03K	ENAMEL	ALNICO 5	VINTAGE	
H/W POBLANO STRAT	6.25K		6.47K		FORMVAR	ALNICO 3	VINTAGE LOW G	CALIBRATED SET
H/W POBLANO STRAT				6.27K	ENAMEL	ALNICO 5	FLUSH	
H/W TOMATILLO STRAT	6.00K	6.00K		6.72K	FORMVAR	ALNICO 2	VINTAGE	
H/W EL DIABLO STRAT	5.55K		5.93K		ENAMEL	ALNICO 5	CUSTOM LOW G	CALIBRATED SET
H/W EL DIABLO STRAT				6.34K	ENAMEL	ALNICO 5	FLUSH w/ HIGH "D"	

\*For base model specifications see page 17

# PICKUP SPECS

\* Enamel wire pickups typically measure lower DCR vs. the same number of turns as FORMVAR

NOMINAL DC RESISTANCE +/- 10%								
HAND-WOUND (Cont.)	NECK	MIDDLE	MID-RWRP	BRIDGE	WIRE	MAGNETS	STAGGER	NOTES
H/W DUAL-MAG	5.79K	6.05K	6.05K	6.27K	FORMVAR	ALNICO 5 UNBEVELED	VINTAGE	CALIBRATED SET
H/W DUAL-MAG	5.79K	6.05K	6.05K	6.27K	FORMVAR	ALNICO 2 BEVELED	VINTAGE	
H/W DUAL-MAG II	5.85K	5.90K	5.90K	5.95K	FORMVAR	ALNICO 5 UNBEVELED	CUSTOM LOW G	CALIBRATED SET
H/W DUAL-MAG II	5.85K	5.90K	5.90K	5.95K	FORMVAR	ALNICO 2 BEVELED	CUSTOM LOW G	
H/W BONE TONE	5.96K	6.21K		5.95K	FORMVAR	ALNICO 2	VINTAGE	
H/W TROPOSPHERE	5.57k	5.56	5.62k	5.62k	FORMVAR	ALNICO 5	VINTAGE	
H/W FAT '64 STRAT	5.90K		5.98K	6.05K	ENAMEL	ALNICO 5	VINTAGE	

NOMINAL DC RESISTANCE +/- 10%								
NON HAND-WOUND STRAT	NECK	MIDDLE	MID-RWRP	BRIDGE	WIRE	MAGNETS	STAGGER	NOTES
50S STRATOCASTER	6.12K	6.12K	6.12K	6.39K	FORMVAR	ALNICO 5	VINTAGE	
60S STRATOCASTER	5.83K	5.83K	5.83K	5.83K	FORMVAR	ALNICO 2	VINTAGE	
65 STRATOCASTER	6.27K	6.27K	6.27K	6.27K	POLYSOL	ALNICO 5	VINTAGE	
66 STRATOCASTER	5.61K	5.61K	5.61K	5.61K	ENAMEL	ALNICO 5	VINTAGE	
TEXAS SPECIAL STRAT	5.94K	6.27K	6.27K	6.56K	ENAMEL	ALNICO 5	VINTAGE	CALIBRATED SET
FAT 50'S CUSTOM SHOP	6.26K	6.34K	6.48K	6.48K	FORMVAR	ALNICO 5	VINTAGE	CALIBRATED SET
69 STRAT CUSTOM SHOP	5.48K	5.48K	5.48K	5.48K	ENAMEL	ALNICO 5	VINTAGE	
FENDER NOISELESS	9.8K	9.8K	9.8K	9.8	POLYSOL	ALNICO 2	CUSTOM	

NOMINAL DC RESISTANCE +/- 10%								
HAND-WOUND TELE	NECK	MIDDLE	MID-RWRP	BRIDGE	WIRE	MAGNETS	STAGGER	NOTES
H/W ORIGINAL BLACKGUARD TELE				10.49K	ENAMEL	ALNICO 5	FLUSH	
H/W '50/'51 BLACKGUARD TELE	7.33K			9.73K	ENAMEL	NECK=ALNICO 5, BRIDGE=ALNICO 3	FLUSH	
H/W CRUSHED BLACKGUARD TELE	10.7K			10.7K	ENAMEL	ALNICO 5	FLUSH	
H/W '51 NOCASTER	7.9K			7.72K	ENAMEL	ALNICO 5	FLUSH	
H/W '51 LOADED NOCASTER	7.88K			9.38K	ENAMEL	NECK=ALNICO 5, BRIDGE=ALNICO 3	FLUSH	
H/W '55/'56 TELECASTER	6.15K			6.12K	ENAMEL	NECK=ALNICO 3, BRIDGE=ALNICO 5	VINTAGE	
H/W '58 TELECASTER	7.4K			6.6K	ENAMEL	ALNICO 5	VINTAGE	
H/W '63 TELECASTER	7.37K			6.59K	ENAMEL	ALNICO 2	VINTAGE	
H/W '64 TELECASTER	7.35K			6.01K	ENAMEL		VINTAGE	
H/W '67 TELECASTER	5.57K			5.99K	ENAMEL		FLUSH	
H/W TOMATILLO TELECASTER	8.7K			9.7K	ENAMEL	ALNICO 2	VINTAGE	

NOMINAL DC RESISTANCE +/- 10%								
NON HAND-WOUND TELE	NECK	MIDDLE	MID-RWRP	BRIDGE	WIRE	MAGNETS	STAGGER	NOTES
51 NOCASTER	7.9K			7.72K	ENAMEL	ALNICO 3	FLUSH	
63 TELECASTER	7.37K			6.59K	ENAMEL	ALNICO 2	VINTAGE	
67 TELECASTER	5.57K			5.99K	ENAMEL	ALNICO 5	VINTAGE	
TEXAS SPECIAL	9.02K			10.16K	ENAMEL	ALNICO 5	VINTAGE	
TWISTED TELE	5.95K			10K	ENAMEL	ALNICO 5	CUSTOM	
RED HOT TELE	8.4K			12.36K	ENAMEL	NECK=ALNICO 2, BRIDGE=ALNICO 5	FLUSH	
NOISELESS	12K			8.6K	ENAMEL	ALNICO 2	CUSTOM	

NOMINAL DC RESISTANCE +/- 10%								
BASS	NECK	MIDDLE	MID-RWRP	BRIDGE	WIRE	MAGNETS	BRIDGE PU STAGGER	NOTES
H/W '55 PRECISION BASS	6.22K				ENAMEL	ALNICO 3	FLUSH	
H/W '57 PRECISION BASS	5.0-5.5			5.0-5.5	ENAMEL	ALNICO 5	HIGH A	
H/W '62 PRECISION BASS	5.2K			5.2K	ENAMEL	ALNICO 5	FLUSH	
H/W 65-70 P-BASS	5.9-6.3K			5.9-6.5K	FORMVAR	ALNICO 5	FLUSH	
H/W VINTAGE JAZZ BASS	7.3K			7.7K	ENAMEL	ALNICO 2	FLUSH	
H/W 75 JAZZ BASS	7.89K			8.16K	ENAMEL	ALNICO 5	FLUSH	
VINTAGE NOISELESS JAZZ BASS	7.25K			7.5K	POLYSOL	ALNICO 2	FLUSH	







# CUSTOMER INFO

## CUSTOMER INFORMATION

NAME: \_\_\_\_\_

ADDRESS: \_\_\_\_\_

\_\_\_\_\_

CITY: \_\_\_\_\_

STATE: \_\_\_\_\_

PHONE #: \_\_\_\_\_

EMAIL: \_\_\_\_\_

DATE: \_\_\_\_\_

STORE: \_\_\_\_\_

CITY: \_\_\_\_\_

SALESPERSON: \_\_\_\_\_

**Final approval, verification and estimated delivery date must be verified by the Fender Custom Shop.**

NOTICE REGARDING USE OF HISTORIC PATENT NUMBERS/MARKINGS: FENDER is proud to offer some of the most iconic musical instruments and amplifiers of the past 60 years. Some FENDER products are intentional recreations or reissues of vintage guitars and amplifiers, and may therefore incorporate markings or text associated with original patents that have since expired. Specific examples of such models include patent numbers on the tremolo plates and decals of the JAGUAR® and JAZZMASTER® guitars, "Pat Pending" on some vintage TELECASTER® guitar bridge plates, and "Design and Circuits Patented" language on the control panels of certain model amplifiers in FENDER Vintage Modified, Vintage Reissue and Custom lines. Such markings are included only for the sake of historical accuracy, and are not intended to denote or imply live patents or ongoing patent protection.



FENDER CUSTOM SHOP | CORONA, CA. | USA

Please contact your Fender Custom Shop Showcase Dealer with your completed Design form for a quote.

To locate the nearest Custom Shop Showcase Dealer please visit [fendercustomshop.com](http://fendercustomshop.com)





For Design Guide orders,  
please use: PN# 7724659000

LIMITED EDITION '60 P BASS® HEAVY RELIC® - AGED  
SHERWOOD GREEN METALLIC - 9235001481